



GANESH INSTITUTE OF
ENGINEERING AND TECHNOLOGY

Electrical Measurement & Instrumentation (Th- 03)

(As per the 2019-20 syllabus of the SCTE&VT,
Bhubaneswar, Odisha)



Fourth Semester

Electrical Engg.

Prepared By:

N.P BALIARSINGH

Th3. ELECTRICAL MEASUREMENT & INSTRUMENTATION

Books Recommended

1. **Electrical & Electronics Measurement & Instrumentation by A K Sawheny**
2. **Electrical and Electronic Measurements and Instrumentation by R.K.Rajput –S Chand**
3. **Electrical Measurement Instrumentation by J.B.Gupta – Katson books**

Sl.No.	Topics	Expected marks
1.	Measuring instruments	05
2.	Analog ammeters and voltmeters	10
3.	Wattmeter and measurement of power	08
4.	Energy meters and measurement of energy	08
5.	Measurement of speed, frequency and power factor	07
6.	Measurement of Resistance, Inductance & Capacitance	08
7.	Sensors And Transducer	09
8.	Oscilloscope	05
TOTAL		100

SYLLABUS

1. MEASURING INSTRUMENTS

Define Accuracy, precision, Errors, Resolutions Sensitivity and tolerance.

1.2 Classification of measuring instruments.

1.3 Explain Deflecting, controlling and damping arrangements in indicating type of instruments.

1.4 Calibration of instruments.

2. ANALOG AMMETERS AND VOLTMETERS

Describe Construction, principle of operation, errors, ranges merits and demerits of:

Moving iron type instruments.

Permanent Magnet Moving coil type instruments.

Dynamometer type instruments

Rectifier type instruments

Induction type instruments

Extend the range of instruments by use of shunts and Multipliers.

Solve Numerical

3. WATTMETERS AND MEASUREMENT OF POWER

Describe Construction, principle of working of Dynamometer type wattmeter. (LPF and UPF type)
The Errors in Dynamometer type wattmeter and methods of their correction.
Discuss Induction type watt meters.

4. ENERGY METERS AND MEASUREMENT OF ENERGY

Introduction

Single Phase Induction type Energy meters – construction, working principle and their compensation & adjustments.

Testing of Energy Meters.

5. MEASUREMENT OF SPEED, FREQUENCY AND POWER FACTOR

Tachometers, types and working principles

Principle of operation and construction of Mechanical and Electrical resonance Type frequency meters.

Principle of operation and working of Dynamometer type single phase and three phase power factor meters.

6. MEASUREMENT OF RESISTANCE, INDUCTANCE & CAPACITANCE

Classification of resistance

- 6.1..1. Measurement of low resistance by potentiometer method. .
- 6.1..2. Measurement of medium resistance by wheat Stone bridge method.
- 6.1..3. Measurement of high resistance by loss of charge method.

Construction, principle of operations of Megger & Earth tester for insulation resistance and earth resistance measurement respectively.

Construction and principles of Multimeter. (Analog and Digital)

Measurement of inductance by Maxwell's Bridge method.

Measurement of capacitance by Schering Bridge method

7. SENSORS AND TRANSDUCER

Define Transducer, sensing element or detector element and transduction elements.

Classify transducer. Give examples of various class of transducer.

Resistive transducer

Linear and angular motion potentiometer.

Thermistor and Resistance thermometers.

Wire Resistance Strain Gauges

Inductive Transducer

Principle of linear variable differential Transformer (LVDT)

Uses of LVDT.

Capacitive Transducer.

General principle of capacitive transducer.

Variable area capacitive transducer.

Change in distance between plate capacitive transducer.

7.6 Piezo electric Transducer and Hall Effect Transducer with their applications.

8. OSCILLOSCOPE

Principle of operation of Cathode Ray Tube.
Principle of operation of Oscilloscope (with help of block diagram).
Measurement of DC Voltage & current.
Measurement of AC Voltage, current, phase & frequency.

Chapter 1 :MEASURING INSTRUMENTS

Measurement: Measurement is the act or the result of a quantitative comparison between a pre-determined standard and unknown quantity.

Measurand: The physical quantity or the characteristics conditions which is the objective of measurement in an instrumentation system is termed as measurand , process variable or instrument variable.

Instrumentation:

- i. The technology of using instruments to measure and control the physical and chemical properties of material is called INSTRUMENTATION.
- ii. Measurement are always made by using an instrument of some kind . Ex- Thermometer, stop watch, Weight measuring instruments etc.

Performance Characteristics: The performances of a system are classified into twotypes.

- i. Static Characteristic
- ii. Dynamic Characteristic

Static Characteristic: Static characteristic of an instrument are the characteristics which doesn't vary with time.

- i. **Accuracy:** It is the closeness with which an instrument reading approaches the true value of the quantity being measured.
- ii. **Precision:**
 - a) It is the degree of exactness or which an system is designed.
 - b)It refers to the degree of arrangement within a group of measurements. It is usually expressed in terms of the deviation in measurement.
- iii. **Error:** It is defined as the difference between the based measured value and true value of the quantity
- iii. **Resolution:** Resolutions the least increment value of input or output that can be detected, caused or otherwise discriminated by the measuring device. It is the smallest change in measurement variable to which an instrument can response .
- iv. **Sensitivity:** Sensitivity can be defined as a ratio of a change output to the change input at steady state condition. it is denoted as **k**.

- v. **Reproducibility:** Reproducibility of an instrument is the closeness of the output for the same value of input. Perfect reproducibility means that the instrument has no drift.

Dynamic characteristics: The Dynamic Characteristics are those which change within a period of time that is generally very short in nature. There are 4 dynamic characteristics.

1. **SPEED OF RESPONSE**-It is the rapidity with which an instrument responds to the changes to in the measurement quantity.
2. **FIDELITY**-The degree to which an instrument indicate the measure variable without dynamic error.
3. **LAG**-It is retardation or delay in the response an instrument to the changes in the measurement.
4. **ERROR-**

Tolerance: It is the range of inaccuracy which can be tolerated by an measuring instrument.

Classification of Measuring Instrument:

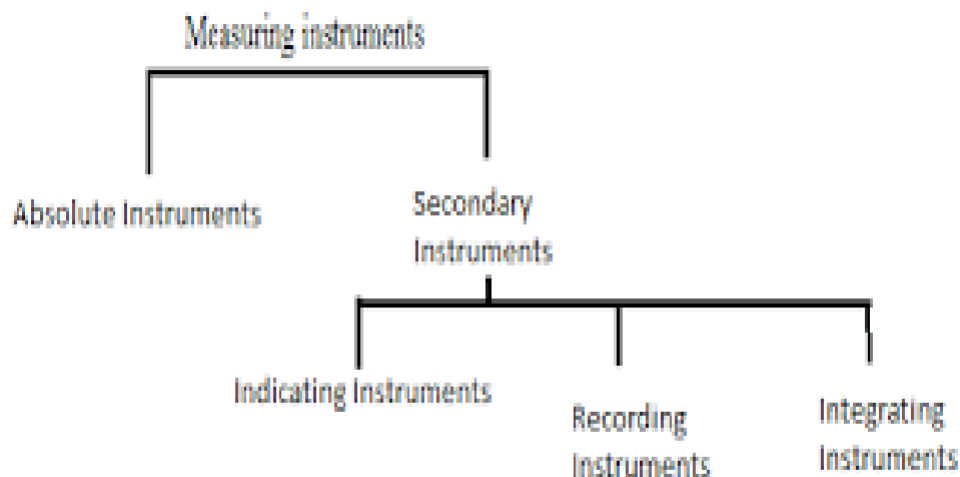

-
- Generally measuring instruments are classified into two categories .i.e absolute instrument and secondary instruments.

Absolute Measuring Instruments: These instruments give output in terms of physical constant of the instruments.

Example- Tangent galvanometers are absolute instruments.

Secondary Measuring Instruments: These instruments are constructed with the help of absolute instruments. Secondary instruments are calibrated by comparison with absolute instruments.

- Again secondary instruments are classified as 3 types i.e. indicating type, Recording type, integrating type.

Indicating: Indicate the quantity to be measured by means of a pointer which moves on a scale. Examples are ammeter, voltmeter, wattmeter etc

Recording: Indicating an instrument that continuously records the values of the measured variable on a chart or dial. The recording is generally made by a pen on a graph paper which is rotated on a disc or drum at a uniform speed. The amount of the quantity at any instant may be read from the traced chart.

Integrating: Records the total quantity of the measured variable over a period of time. Eg: kilowatt-hour (kWh) meter.

Explain Deflecting, controlling and damping arrangements in indicating type of instruments:

There is three type of torque seen in indicating instrument which are as following:-

1. Deflecting torque
2. Controlling torque
3. Damping torque

Deflecting Torque (T_d):-Deflecting torque is the amount of Torque needed for the pointer to move from its zero position.

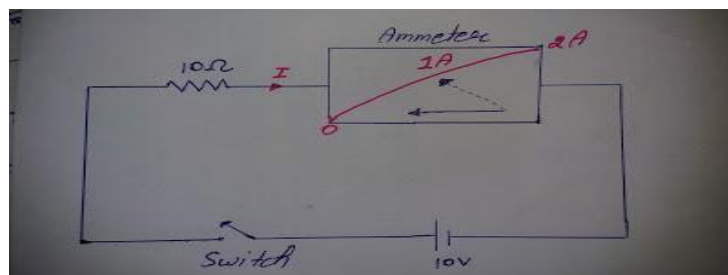

- For the ammeter to indicate a value of 1 ampere of current a torque or force is required which is called deflecting torque and is proportional to current.

Controlling torque(T_c):The controlling torque is in opposite to the deflecting torque at a point where controlling torque and deflecting torque is equal the pointer stops and show the measured value of the reading.

- The controlling torque is also used to bring the pointer to zero initial position if there is a no deflecting torque.

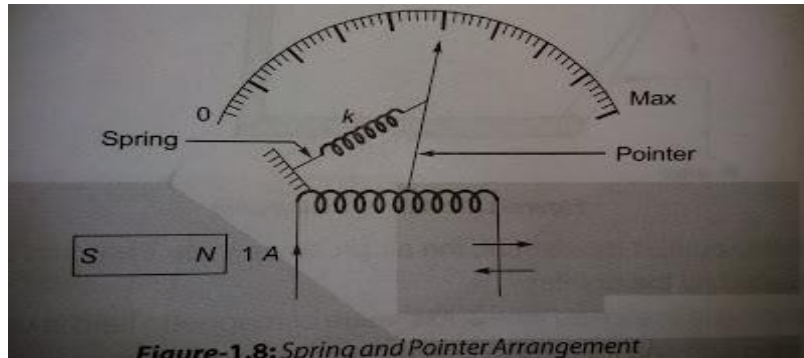

Damping torque(T_k):Damping torque is one which acts on the moving system of the instrument only when it is moving and always opposes its motion.

- Such damping force is necessary to bring the pointer to rest quickly, otherwise due to inertia of the moving system, the pointer will oscillate about its final deflected position for quite some time before coming to rest in the steady position.

Calibration of instruments:

- Calibration is the documented comparison of the measurement device to be calibrated against a traceable reference device.
- Calibration of measuring instruments has 2 objectives:
 - i) To check the accuracy of instruments.
 - ii) To determine traceability of the instruments.

Short questions with answer:

1. Define Precision.

ANS:- The precision of a measurement system is the degree to which repeated measurements under unchanged conditions show the same results.

2. Define Resolution.

ANS:- Resolution is the ability of the measurement system to detect and faithfully indicate small changes in the characteristic of the measurement result.

3. What is the difference between indicating type & integrating type instruments?

ANS:- The value of the electrical quantity is indicated by these instruments at the time when it is being measured. Pointers moving over the scale give the indication in indication type instruments. **EX:-** Ammeters, Voltmeters and watt meters are the examples of these instruments.

The total amount of either electricity or electrical energy supplied over a period of time is measured by integrating type instruments.

EX:- Ampere hour meters, watt-hour meters, energy meters are the few examples of these instruments.

4. What is Deflecting torque?

ANS:- The torque due to which pointer of a measuring instruments deflect from its zero position is called deflecting torque.

5. Define Accuracy.

ANS:- The degree to which the result of a measurement, calculation, or specification conforms to the correct value or a standard.

6. Define Tolerance.

ANS:- A tolerance is a positive or negative amount by which a designer may allow a manufactured item to deviate from an ideal value.

7. Define sensitivity.

ANS:- The smallest change that can be detected by a measuring instrument

Long questions:

1. What are the different types of damping? Explain it in brief.
2. Explain deflecting, controlling, damping torque in indicating instruments.
3. Briefly explain different types of torque in an Indicating type of instruments.

Chapter 2 : ANALOG AMMETERS AND VOLTMETERS

Introduction:

- Voltmeter and Ammeter are essential for voltage and current measurement.
- The ammeter has low resistance so that when it connected in series with any circuit it doesn't change the current value.
- The voltmeter has high resistance and is so designed that when it connected parallel with the circuit for measuring the voltage .

Types of Instruments used as ammeter and voltmeter:

- Moving Iron type (MI type)
- Permanent Magnet Moving Coil (PMMC type)
- Electrodynamic type
- Rectifier type
- Electrostatic type
- Induction type

Moving Iron Type (MI type) Instruments:

- The most common type of ammeter and voltmeter used for laboratory or switchboard at power frequency are the MI type instruments

- MI type instruments are used for measurement for AC and DC quantities.
- There are two type of MI type instruments
 - I) Attraction Type
 - II) Repulsion Type

1. Attraction Type Instruments-The instrument in which the iron plate attracts from the weaker field towards the stronger field such type of instrument is known as the attraction type instrument.

Construction of Attraction Type Instrument – The stationary coil of the attraction type instrument is flat and has a narrow opening. The moving element is the flat disc of the iron core. The current flow through the stationary coil produced the magnetic field which attracts the iron coil.

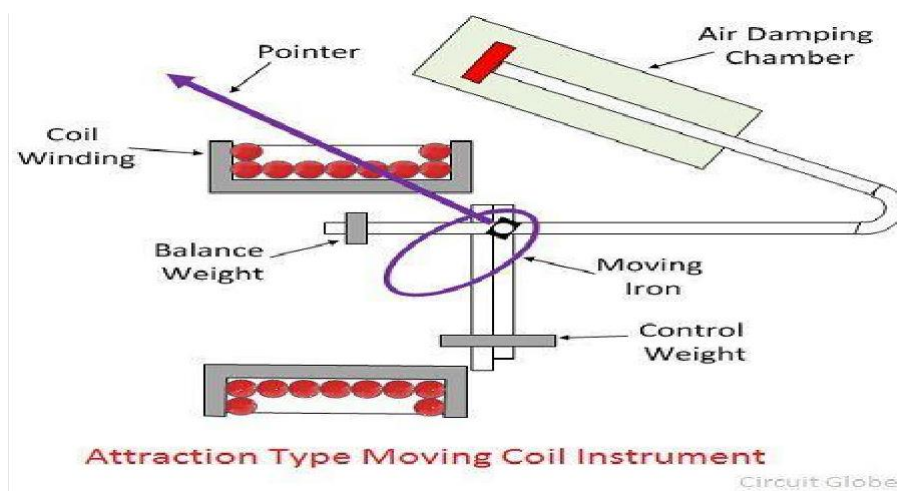

The iron vane deflects from the low magnetic field to the high magnetic field, and the strength of the deflection is directly proportional to the magnitude of the current flow through it. In short, we can say that the iron coil attracts towards in.

The attraction type instruments use spring, which provided the controlling torque. The deflection of the coil is reduced by the aluminium piston which is attached to the moving coil.

2. Repulsion Type Instruments – The repulsion type instrument has two vanes or iron plates. One is fixed, and the other one is movable. The vanes become magnetised when the current passes through the stationary coil and the force of repulsion occur between them.

Because of a repulsive force, the moving coil starts moving away from the fixed vane.

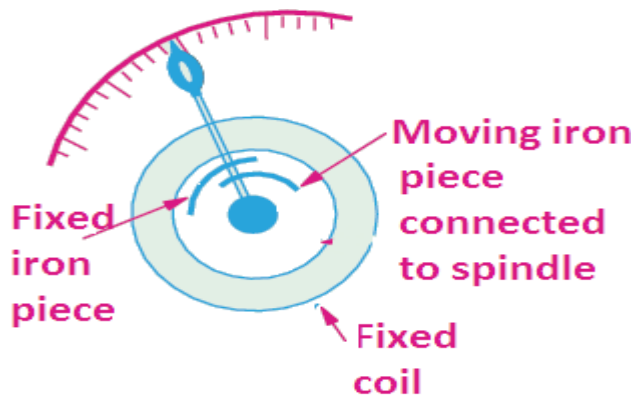

Repulsion type instrument

The spring provides the controlling torque. The air friction induces the damping torque, which opposes the movement of the coil. The repulsion type instrument is a non-polarized instrument, i.e., free from the direction of current passes through it. Thus, it is used for both AC and DC.

Torque equation in MI type Instruments:

Torque equation of moving iron instruments can be draw by energy relation.

$$T_d \cdot d\theta = \frac{1}{2} I^2 dL$$

$$T_d = \frac{1}{2} I^2 \frac{dL}{d\theta}$$

where

T_d = Deflection torque

θ = deflection and

L = coil inductance

Controlling Torque T_c is provided by controlling spring. Deflection torque is balanced by Controlling torque $T_c = K \theta$

Where K = Control Spring constant Nm/rad.

$$T_c = K \theta$$

Where K = spring constant

$$K \theta = \frac{1}{2} I^2 \frac{dL}{d\theta}$$

$$\theta = \frac{1}{2} \frac{I^2}{K} \frac{dL}{d\theta}$$

Errors with both AC and DC:

The following are the main **errors in moving iron instruments**, when these are used either on DC or AC.

- **Error due to hysteresis:** Because of hysteresis in the iron parts of the operating system, the readings are higher for descending values but lower for ascending values. The hysteresis error is considerably reduced by using mumetal or permalloy which have negligible hysteresis loss.
- **Error due to stray magnetic fields:** Since the operating magnetic field of the moving iron instruments is comparatively weak, therefore, stray fields (fields other than the operating magnetic field) affect these instruments considerably. Thus the stray fields cause serious errors. These errors can be minimized by using an iron case or a thin iron shield over the working parts.
- **Error due to temperature:** The effect of temperature change on moving iron instrument arises mainly from the temperature coefficient of spring. With the change in temperature stiffness of the spring varies which causes errors. However, for voltmeters, both the temperature coefficient of spring and temperature coefficient of resistance of voltmeter circuit may balance each other.

Errors with AC only

- **Error in moving iron instruments due to change in frequency:** The change in frequency produces a change in impedance of the coil and change in magnitude of eddy currents. The increase in impedance of the coil with the increase in frequency causes serious errors in case of voltmeters only. However, this error can be eliminated by connecting a condenser of suitable value in parallel with the swamp resistance 'r' of the instrument. The impedance of the whole circuit of the instrument becomes independent of frequency if $C = L/r^2$, where C is the capacitance of the condenser.

Advantages of Moving Iron Instruments

- The moving iron instruments are cheap, robust and simple in construction.
- These instruments can be used on both AC and DC.
- These instruments are reasonably accurate.
- The moving iron instruments possess high operating torque.
- These instruments can withstand overloads momentarily.

Disadvantages of Moving Iron Instruments

- The scale of moving iron instrument is non-uniform; crowded at the beginning, therefore, accurate readings are not possible at this end.
- These instruments are not very sensitive.
- Power consumption is quite high in the moving iron instruments.
- Errors are introduced due to change in frequency in case of AC measurements.

Permanent Magnet Moving Coil (PMMC type) Instruments:

Definition: The instruments which use the **permanent magnet** for **creating the stationary magnetic field** between which the **coil moves** is known as the permanent magnet moving coil or PMMC instrument.

Construction of PMMC Instrument:

The moving coil and permanent magnet are the main part of the PMMC instrument.

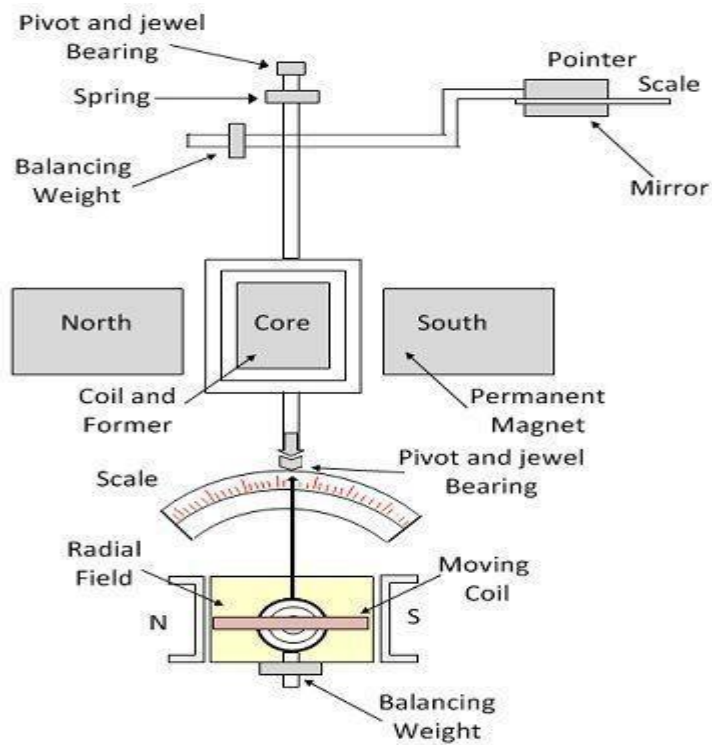

Permanent Magnet Moving Coil Instrument

Circuit Globe

Moving Coil – The coil is the current carrying part of the instruments which is freely moved between the stationary field of the permanent magnet. The current passes through the coil deflects it due to which the magnitude of the current or voltage is determined. The coil is mounted on the rectangular former which is made up of aluminium. The former increases the radial and uniform magnetic field between the air gap of the poles. The coil is wound with the silk cover copper wire between the poles of a magnet.

The coil is mounted on the rectangular former which is made up of aluminium. The former increases the radial and uniform magnetic field between the air gap of the poles. The coil is wound with the silk cover copper wire between the poles of a magnet.

Magnet System – The PMMC instrument using the permanent magnet for creating the stationary magnets. The Alcomax and Alnico material are used for creating the permanent magnet because this magnet has the high coercive force (The coercive force changes the magnetisation property of the magnet). Also, the magnet has high field intensities.

Control – In PMMC instrument the controlling torque is because of the springs. The springs are made up of phosphorous bronze and placed between the two jewel bearings. The spring also provides the path to the lead current to flow in and out of the moving coil. The controlling torque is mainly because of the suspension of the ribbon.

Damping – The damping torque is used for keeping the movement of the coil in rest. This damping torque is induced because of the movement of the aluminium core which is moving between the poles of the permanent magnet.

Pointer & Scale – The pointer is linked with the moving coil. The pointer notices the deflection of the coil, and the magnitude of their deviation is shown on the scale. The pointer is made of the lightweight material, and hence it is easily deflected with the movement of the coil. Sometimes the parallax error occurs in the instrument which is easily reduced by correctly aligning the blade of the pointer.

Torque Equation for PMMC Instrument:

The deflecting torque induces because of the movement of the coil. The deflecting torque is expressed by the equation shown below.

$$T_d = NBLdI \dots \text{equ}(1)$$

Where, N – Number of turns of coil

B – flux density in the air gap

L, d – the vertical and horizontal length of the side.

I – current through the coil. $G = NBLd \dots \text{equ}(2)$

The spring provides the restoring torque to the moving coil which is expressed as

$$T_c = K\theta \dots \text{equ}(3)$$

Where K = Spring constant.

For final deflection,

$$T_c = T_d$$

By substituting the value of equation (1) and (3) we get,

$$K\theta = GI$$

$$\theta = \frac{GI}{K} \dots \text{equ}(4)$$

$$I = \frac{K}{G}\theta \dots \text{equ}(5)$$

The above equation shows that the deflection torque is directly proportional to the current passing through the coil.

Error in PMMC Instruments:

1. Magnet – The heat and vibration reduce the lifespan of the permanent magnet. This treatment also reduced the magnetism of the magnet. The magnetism is the property of the attraction or repulsion of the magnet. The weakness of the magnet decreases the deflection of the coil.

2. Springs – The weakness of the spring increases the deflection of moving coil between the permanent magnet. So, even for the small value of current, the coil show large deflection. The spring gets weakened because of the effect of the temperature. One degree rise in temperature reduces the 0.004 percent life of the spring.

3. Moving Coil – The error exists in the coil when their range is extended from the given limit by the use of the shunt. The error occurs because of the change of the coil resistance on the shunt resistance. This happens because the coil is made up of copper wire which has high shunt resistance and the shunt wire made up of Magnin has low resistance.

- To overcome from this error, the swamping resistance is placed in series with the moving coil. The resistor which has low-temperature coefficient is known as the swamping resistance. The swamping resistance reduces the effect of temperature on the moving coil.

Advantages of PMMC Instruments:

The following are the advantages of the PMMC Instruments.

1. The scale of the PMMC instruments is correctly divided.
2. The power consumption of the devices is very less.
3. The PMMC instruments have high accuracy because of the high torque weight ratio.
4. The single device measures the different range of voltage and current. This can be done by the use of multipliers and shunts.
5. The PMMC instruments use shelf shielding magnet which is useful for the aerospace applications.

Disadvantages of PMMC Instruments:

The following are the disadvantages of the PMMC instruments.

1. The PMMC instruments are only used for the direct current. The alternating current varies with the time. The rapid variation of the current varies the torque of the coil. But the pointer can not follow the fast reversal and the deflection of the torque. Thus, it cannot use for AC.
2. The cost of the PPMC instruments is much higher as compared to the moving coil instruments.

Uses:

- These instruments are used for the measurement of DC current and voltage.

Dynamometer type instruments: These instruments are the modified form of permanent magnet moving coils type

Principle of Dynamometer type instruments:

These instruments are based on that principle the mechanical force exists between the current carrying conductors.

Construction of Dynamometer type instruments:

A dynamometer type instrument as shown in fig essentially consists of a fixed coil and a moving coil. The fixed coil is split into two equal parts which are placed close together and parallel to each other. The moving coil is pivoted in between the two fixed coils. The fixed and moving coils may be excited separately or they may be connected in series depending upon the use to which the measurement is put. The moving coil is attached to the moving system so that under the action of deflecting torque, the pointer moves over the scale.

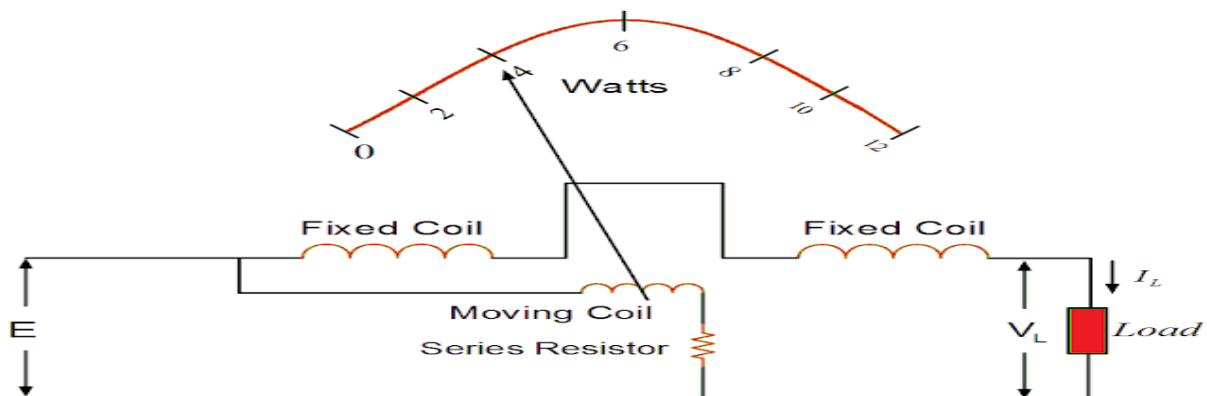

The controlling torque is provided by two springs which also serve the additional purpose of leading the current into and out of the moving coil. Air friction damping is provided in such instruments.

Working of Dynamometer type instruments:

When instrument is connected in the circuit, operating currents flow through the coils. Due to this, mechanical force exists between the coils. The result is that the moving coil moves the pointer over the scale. The pointer comes to rest at a position where deflecting torque is equal to the controlling torque.

By reversing the current, the field due to fixed coils is reversed as well as the current in the moving coil, so that the direction of deflecting torque remains unchanged. Therefore, such instruments can be used for both d.c and a.c measurements.

Deflecting torque of Dynamometer type instruments:

Let

I_f = current through fixed coil

I_m = current through moving coil

Since $I_f = I_m$ because the fixed and coils are in series,

$$T_d = I^2$$

Since the control is by springs, therefore,

controlling torque is proportional to the angle of deflection

T_c proportional deflection

The pointer will come to rest at a position when $T_d = T_c$

Advantages of Dynamometer type instruments:

1. These instruments can be used for both a.c and d.c measurements.
2. Such instruments are free from hysteresis and eddy current errors.

Disadvantages of Dynamometer type instruments:

1. Since torque / weight ratio is small, therefore, such instruments have frictional errors which reduce sensitivity.
2. Scale is not uniform.
3. A good amount of screening of the instruments are required to avoid the effect of stray fields.
4. These instruments are costlier than types and, therefore, they are rarely used as ammeters and voltmeters.

Uses:

- These instruments are used for the measurement of DC and AC quantities.
- Used in the operation of Wattmeter.

Rectifier type instruments:

The rectifying element converts the alternating current to the direct current which indicates by the DC responsive meter. The PMMC uses as an indicating instrument.

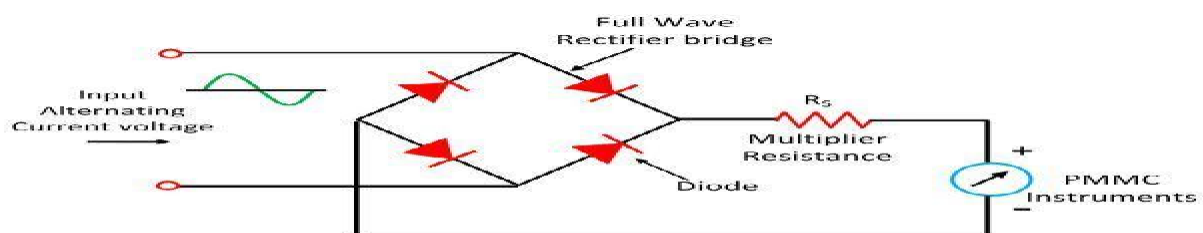

Rectifier type Instrument are of two type:

1. Half wave Rectifier
2. Full wave Rectifier

Half wave Rectifire:

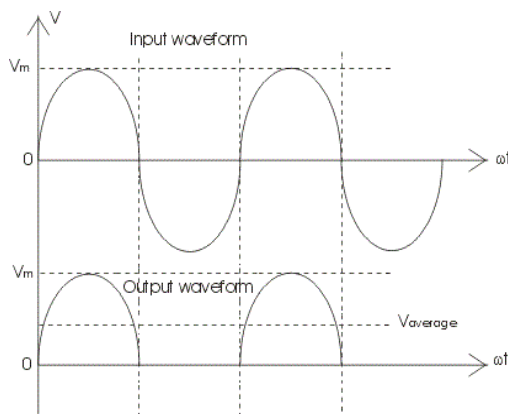
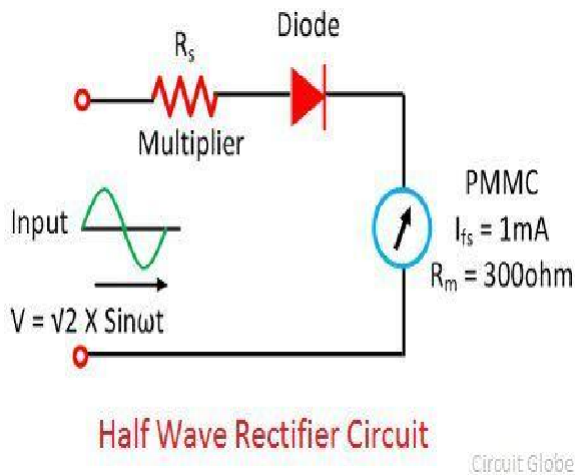

The rectifying element converts the AC voltage into unidirectional DC voltage. Thus, the rectified output voltage obtains through the rectify instrument. The PMMC instrument deflects through the average value of current which depends on the average voltage of the apparatus.

$$V_{av} = \frac{1}{2\pi} \int_0^{\pi} V_m \sin\omega t d(\omega t) = \frac{1}{\pi} V_m$$

$$V_{av} = 0.318V_m$$

$$V_{av} = 0.318 \times \sqrt{2V} = 0.45V$$

Full wave Rectifier:

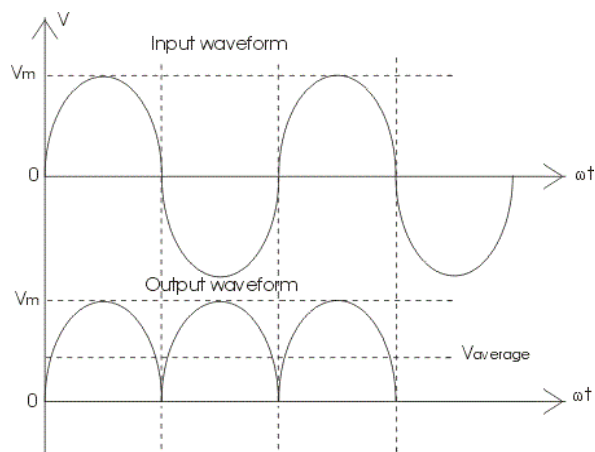
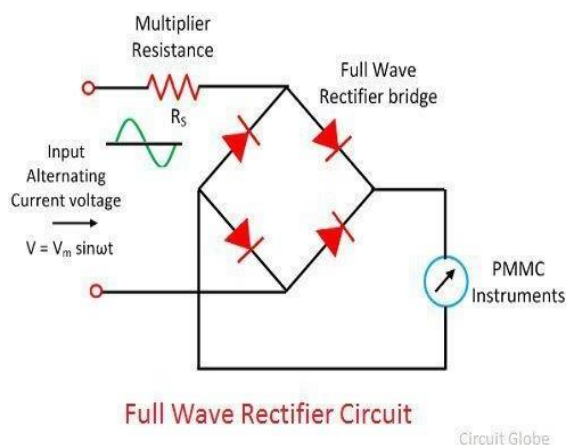

The DC voltage applied to the circuit causes the full-scale deflection of the PMMC meter. The sinusoidal voltage applies to the meter express as

$$V_{av} = \frac{1}{\pi} \int_0^{\pi} V_m \sin \omega t d(\omega t) = \frac{2}{\pi} V_m$$

$$V_{av} = 0.636 V_m$$

$$V_{av} = 0.9V$$

Advantages of Rectifying Instrument:

1. The frequency range of the instruments increases from 20HZ to high-frequency range.
2. The current operating range for such type of instrument is much lower for voltmeter as compared to the other AC instrument.
3. The instrument has uniform scales for the large range.
4. The accuracy of the instrument is ± 5 percent when it is in normal operating condition.

Applications of Rectifying Instrument:

1. The instrument uses for measuring the voltage whose range lies between 50 – 250 V.
2. It use as a milliammeter or micro-ammeter.
3. The rectifying instrument use in the communication circuit for measurement.

Induction type instruments:

- In all induction meters two fluxes which are produced by two different alternating currents on a metallic disc. Due to alternating fluxes there is an induced emf, the emf produced at one point interacts with the alternating current of the other side resulting in the production of torque.
- The emf produced at the point two interacts with the alternating current at point one, resulting in the production of torque again but in opposite direction. Hence due to these two torques which are in different directions, the metallic disc moves.

Torque Equation:

- Let us take flux produced at point one be equal to F_1 and the flux and at point two be equal to F_2 . Now the instantaneous values of these two flux can written as:

$$F_1 = F_{m1} \sin \omega t, \quad F_2 = F_{m2} \sin(\omega t - B)$$

- Where, F_{m1} and F_{m2} are respectively the maximum values of fluxes F_1 and F_2 , B is phase difference between two fluxes.

We can also write the expression for induced emf's at point one be

$$E_1 = -\frac{d(F_1)}{dt} \quad \text{and} \quad E_2 = -\frac{d(F_2)}{dt}$$

- Thus we have the expression for eddy currents at point one is

$$I_1 = \frac{E_1}{Z} = K \times f \times F_1$$

- Where, K is some constant and f is frequency. the expression for deflecting torque as

$$T_{d1} = K \times F_2 \times I_1 \times \cos(90 - B + A) = K \times F_1 \times F_2 \times \frac{f}{Z} \cos(90 - B + A),$$

Similarly the expression for T_{d2} is,

$$T_{d2} = K \times F_1 \times F_2 \times \frac{f}{Z} \cos(90 + A + B)$$

- The total torque is $T_{d1} - T_{d2}$, on substituting the the value of T_{d1} and T_{d2} and simplifying the expression we get

$$T_{d1} - T_{d2} = K \times F_1 \times F_2 \times \frac{f}{Z} \sin(B) \cos(A),$$

Which is known as the general expression for the deflecting torque in the **induction type meters**

Extend the range of instruments by use of shunts and Multiplier

- Extension of Range of Ammeter by Shunt

- It is possible to extend the range of an ammeter by using a shunt. A shunt is a low-value resistance having minimum temperature co-efficient and is connected in parallel with the ammeter whose range is to be extended. The combination is connected in series with the circuit whose current is to be measured.
- This shunt provides a bypath for extra current because it is connected across (i.e. in parallel with) the instrument.
- These shunted instruments can be used to measure currents many times greater than their normal full-scale deflection current
- The ratio of maximum current (with shunt) to the full-scale deflection current (without shunt) is known as the 'multiplying power' or 'multiplying factor' of the shunt.
- **Example:** A moving coil ammeter reading up to 1 ampere has a resistance of 0.02 ohm. How could this instrument be adopted to read current up to 100 amperes.

Solution: In this case,

Full-scale deflection current of the ammeter, $I_m = 1 \text{ A}$

Line current to be measured, $I = 100 \text{ A}$

Resistance of ammeter, $R_m = 0.02 \text{ ohm}$

Let, the required shunt resistance = S

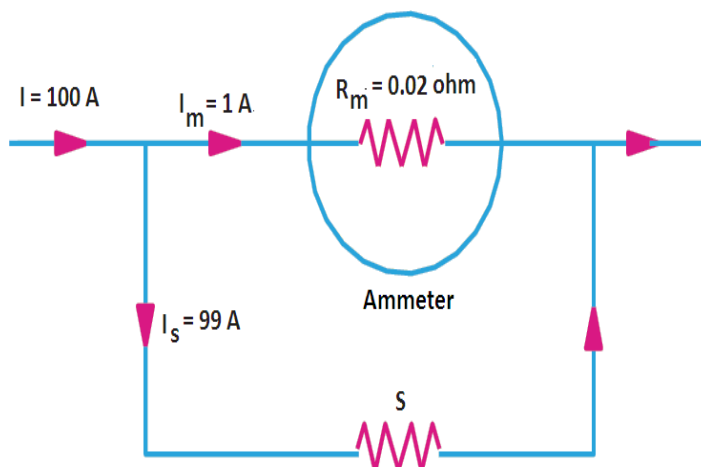

-
- As seen from Figure, the voltage across the instrument coil and the shunt resistance

is the same since
both are joined in parallel.

$$\therefore I_m * R_m = S * I_s = S(I - I_m)$$

$$\text{or } S = I_m * R_m / (I - I_m)$$

$$= 1 * 0.02 / (100 - 1) = 0.02 / 99 = 0.000202 \text{ Ans.}$$

- **Extension of Range of Voltmeter by Multipliers**



Multipliers are used for the range extension of voltmeters. The multiplier is a non-inductive high-value resistance connected in series with the instrument whose range is to be extended.

➤ The combination is connected across the circuit whose voltage is to be measured.

Example: A moving coil voltmeter reading up to 20 mV has a resistance of 2 ohms. How this instrument can be adopted to read voltage up to 300 volts.

Solution: In this case,

Voltmeter resistance, $R_m = 2 \text{ ohm}$

Full-scale voltage of the voltmeter, $v = R_m I_m = 20 \text{ mV} = 0.02 \text{ V}$

Full-scale deflection current, $I_m = v / R_m = 0.02 / 2 = 0.01 \text{ A}$

Voltage to be measured, $V = 300 \text{ V}$

Let the series resistance required = R

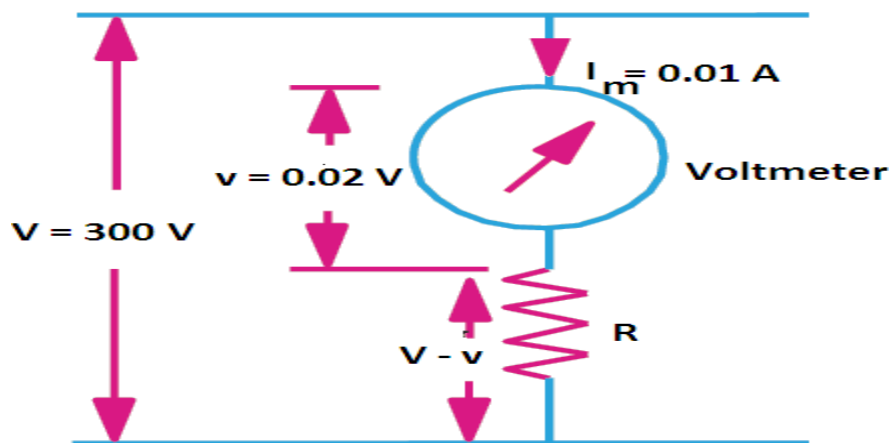

Then as seen from figure, the voltage drop across R is $V - v$

$$R * I_m = V - v$$

$$\text{or } R = (V - v) / I_m$$

or $R = (300 - 0.02)/0.01 = 299.98/0.01 = 29998$ ohms Ans.

Advantages:

1. They are inexpensive as compared to moving iron type instruments.
2. They have high torque is to weight ratio as compared to other instruments.
3. They retain their accuracy over wide range of temperature as well as loads.

Short questions with answer:

1. Which type of instruments are mainly used for Ammeter and Voltmeter?

Ans-MI type instruments are mainly used for Ammeter and Voltmeter.

2. What are the errors in PMMC type instruments?

Ans-i) Error due to Magnet **ii)**Error due to effect of spring **iii)**Error due to temperature.

3. Which type of instruments is used for DC measurement?

Ans-PMMC instruments used for DC measurement only.

4. Why the scale of PMMC type instrument is uniform?

Ans-Because the magnetic line of force in a permanent magnet is uniform.

5. What is the basic principle of Rectifier type instruments?

Ans- The basic principle of Rectifier type instrument is to convert AC to pulsating DC

Long type questions:

1. Explain the working of M.I. type instruments with necessary diagram & Derive the expression of the torque
 2. with a neat diagram explain the working of a PMMC type instrument.
 3. Explain Rectifier type instruments.
 4. State with Example how can you Extend the range of PMMC type instruments
 5. Discuss the Errors in a PMMC instruments
-

Chapter 3: WATTMETERS AND MEASUREMENT OF POWER

Dynamometer type wattmeter:

- A dynamometer type wattmeter is basically a moving coil instrument. A wattmeter in which fixed coils produce the operating field is known as a dynamometer type wattmeter.

Dynamometer Type Wattmeter Working Principle:

In these wattmeters, the field produced by the current-carrying moving coil tries to come in line with the field produced by the current-carrying fixed coil, and a deflecting torque is exerted on the moving system. As a result, deflection takes place in the pointer.

Construction of Dynamometer Type Wattmeter:

- A dynamometer type wattmeter primarily consists of two coils called fixed coil and moving coil. The fixed coil is splitted into two equal parts, which are placed parallel to each other.
- The fixed coil is connected in series with the load and carries the circuit current. It is, therefore, called the current coil. Since current coils carry full load current, so these are made up of thick wire. And current flow through them is high, so few turns are sufficient to produce the desired magnetic field.

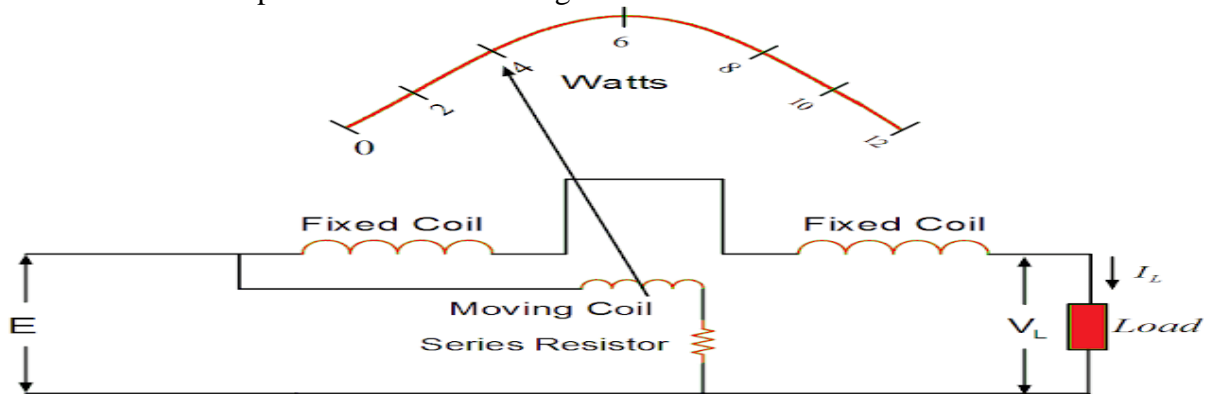

- A high resistance is connected in series with the moving coil to limit the current through it. The springs provide the controlling torque. Air friction damping is employed in this type of instruments.
- Its current coil is connected in series with the load, carries the load current, and the potential coil, connected in parallel with the load.

Dynamometer Type Wattmeter Working:

- The fixed coil produces a field F_m , and the moving coil creates a field F_r . The field F_r tries to come in line with the main field F_m , which provides a deflecting torque on the moving coil. Thus, the pointer attached to the spindle of the moving coil deflects. This deflection is controlled by the controlling torque produced by the springs.

Advantages :

- It can be used both on AC and DC circuits.
- It has a uniform scale.
- We can obtain a high degree of accuracy through careful design.

Disadvantages :

- At low power factors, the inductance of the potential coil causes serious errors.
- The reading of the instrument may be affected by stray fields acting on the moving coil. To prevent it, magnetic shielding is provided by enclosing the instrument in an iron case.

Errors in Dynamometer Type Wattmeter and correction :The following are severe errors in this type of wattmeter:

1. Error due to potential coil inductance: The inductance of the potential coil is liable to

cause an error in the reading of the wattmeter. Because of this error, the wattmeter gives a high reading on the lagging power factor and low reading on the leading power factor.

The high non-inductive resistance connected in series with the coil swamps the phasing effect of the potential coil inductance.

2. Error due to power loss in the potential coil or current coil: Another possible error in the indicated power may be due to some voltage drop in the current coil or the current taken by the potential coil.

We can overcome this defect by using an additional compensating winding. This winding is connected in series with the potential coil and so placed that it produces a field in the opposite direction to that of the current coils.

3. Error due to eddy currents: The alternating field of fixed or current coil induces eddy currents in the solid metal parts which set up their own magnetic field. This alters the magnitude and phase of the magnetic field, causing deflection.

Thus an error is introduced in the instrument reading. To reduce this error, the solid metal parts are placed as far away as possible from the current coil.

4. Error due to the stray magnetic field: The dynamometer type wattmeter has a relatively weak operating field; therefore, stray fields affect the reading of this instrument considerably and cause serious errors.

Hence, this type of instrument must be shielded against stray magnetic fields by using iron cases or providing thin iron shields over the working parts.

Induction Type Wattmeter: The induction type wattmeter is used to measure a.c power only.

Principle of Induction type wattmeter:

- The principle of operation of an induction wattmeter is same as that of induction ammeters and voltmeters i.e. induction principle. However, it differs from induction ammeter or voltmeter in so far that separate two coils are used to produce the rotating flux in place of one coil with phase split arrangement.

Construction of Induction type wattmeter:

- It consists of two laminated electromagnets. One electromagnet, called shunt magnet is connected across supply and carries current proportional to the applied voltage.
- The coil of this magnet is made highly inductive so that the current in it lags behind the supply voltage by 90 degrees. The other electromagnet, called series magnet is connected in series with supply and carries the load current.
- The coil of this magnet is made highly non inductive so that the angle of lag or lead is determined fully by the load.

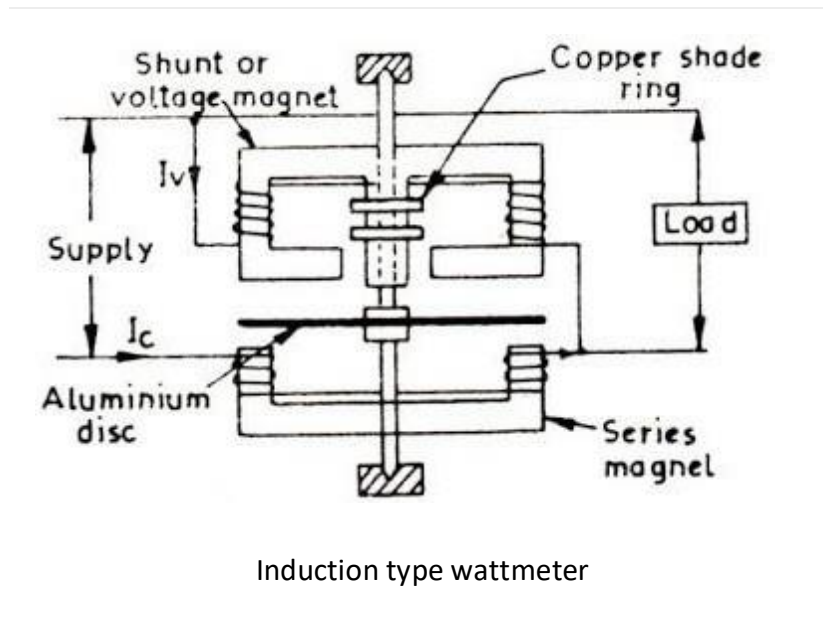

- A thin aluminium disc mounted on the spindle is placed in between the two magnets so that it cuts the fluxes of both the magnets.
- The controlling torque is provided by spiral springs. The damping is electromagnet and is usually provided by a permanent magnet embracing the aluminium disc.
- Two or more closed copper rings, called shading rings are provide on the central limb of the shunt magnet.
- By adjusting the position of these rings, the shunt magnet flux can be made to lag behind supply voltage by exactly 90degrees.

Working of Induction type wattmeter:

- When the wattmeter is connected in the circuit to measure a.c power, the shunt magnet carries current proportional to the supply voltage and the series magnet carries the load current.
- The two fluxes produced by the magnets induce eddy currents in the aluminium disc. The interaction between the fluxes and eddy currents produce the deflecting torque on the disc, causing the pointer connected to the moving system to move over the scale.

Advantages:

- They are inexpensive as compared to moving iron type instruments.
- They have high torque is to weight ratio as compared to other instruments.
- They retain their accuracy over wide range of temperature as well as loads.

Short questions with answer:

1. What is the necessary of copper shading coil in the pressure coil of Induction type Wattmeter?

Ans- (A) Bring flux exactly in quadrature with applied voltage **(B)** To increase speed of aluminum disc **(C)** To count the rotation **(D)** To balance the system from vibration

2. Is Induction type wattmeter used in DC?

Ans-NO Induction type instruments are not used in DC.

3. Draw the schematic diagram of wattmeter?

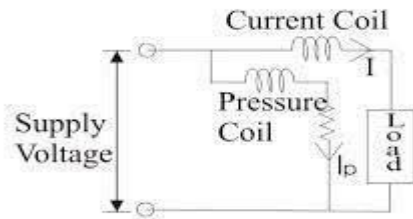

Ans -

4. How the compensation for induction of a pressure coil can be done?

ANS-BY connecting a capacitor with the a pressure coil .

Long type questions:

1. State the error in dynamometer type watt meter & Method of their correction.
 2. Explain the working principle of Dynamometer type watt meter.
 3. With neat diagram explain Working of Induction type watt meter.
-
-

Chapter-4 :ENERGYMETERS AND MEASUREMENT OF ENERGY

4.1.1 Single phase Induction type Energy Meter:

Principle:

The basic principle of induction type energy meter is electromagnetic induction. When alternating current flow through two coils produces rotating magnetic field which is cut by the metallic disc suspended near to the coils thus emf induce in the disc which circulates eddy current in it. By interaction of rotating magnetic field and eddy currents, torque is developed and cause the disc rotate.

Construction:

An induction type single phase energy meter, as show in fig has following main parts of the operating mechanism.

1. Driving system.
2. Moving system.
3. Breaking system.
4. Recording mechanism.

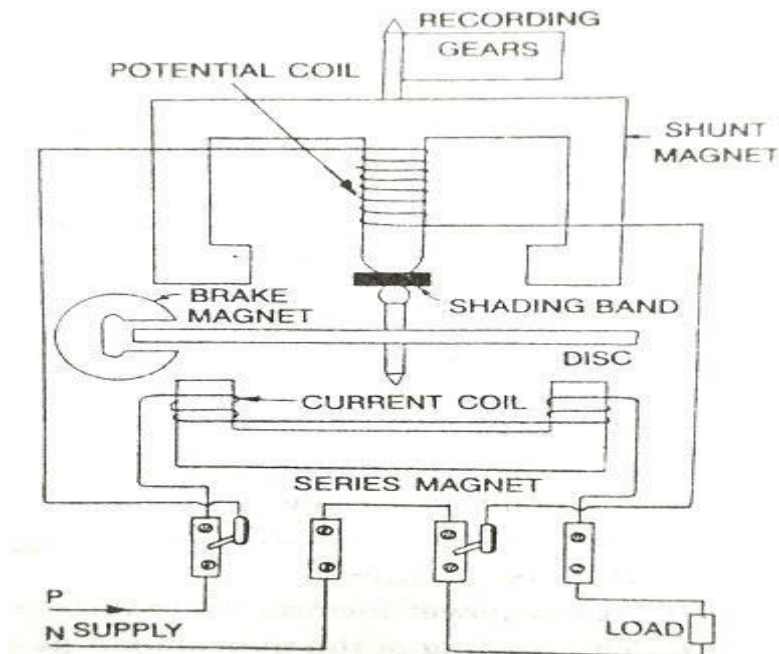

Driving System:

- Driving system consists of two electromagnets on which pressure coil and current coils are wound, as shown above in the diagram.
- The coil which consist of load current is called current coil while coil which is in parallel with the supply voltage is called pressure coil.
- Shading bands are wound on as shown above in the diagram so as to make angle between the flux and and applied voltage equal to 90 degrees.

Moving System:

- The moving system is the aluminum disc mounted on the shaft of the alloy. The disc is placed in the air gap of the two electromagnets.
- When the devices consume power, the aluminum disc starts rotating, and after some number of rotations, the disc displays the unit used by the load.
- The number of rotations of the disc is counted at particular interval of time. The disc measured the power consumption in kilowatt hours.

Braking System:

- A permanent magnet is used to produce braking torque in single phase induction energy meters which are positioned near the corner of the aluminum disc.

Recording system:

- The function of recording or registering mechanism is to record continuously a number on the dial which is proportional to the revolutions made by the moving system.

Working of the Energy Meter:

- The energy meter has the aluminium disc whose rotation determines the power consumption of the load. The disc is placed between the air gap of the series and

shunt electromagnet. The shunt magnet has the pressure coil, and the series magnet has the current coil.

- The pressure coil creates the magnetic field because of the supply voltage, and the current coil produces it because of the current.
- The field induced by the voltage coil is lagging by 90° on the magnetic field of the current coil because of which eddy current is induced in the disc. The interaction of the eddy current and the magnetic field causes torque, which exerts a force on the disc. Thus, the disc starts rotating.
- The force on the disc is proportional to the current and voltage of the coil. The permanent magnet controls their rotation. The permanent magnet opposes the movement of the disc and equalises it on the power consumption. The cyclometer counts the rotation of the disc.

Advantages:

1. They are inexpensive as compared to moving iron type instruments.
2. They have high torque to weight ratio as compared to other instruments.
3. They retain their accuracy over wide range of temperature as well as loads.

Compensation and Adjustments:

Compensation:

- **Voltage Compensation :** The errors due to voltage variations are compensated by increasing the reluctance of side limbs of shunt magnet. Holes are provided on the side limbs of shunt magnet for this purpose.
- **Temperature Compensation :** Owing to temperature effects, the energy meters may run faster and register wrong values. In such cases, the compensation is provided by a temperature shunt on the brake magnet.
- **Over load Compensation :** Over load compensators are used to minimize the self braking action of energy meters. They are in the form of a saturable magnetic shunt for the series magnet.

Adjustments:

- **Preliminary Light Load Adjustment:** Rated voltage is applied to potential coil with no current in the current coil. The light load device is adjusted until the disc just fails to start. In this adjustment, care should be taken to see that the disc is positioned in such a way that the holes do not come under the electromagnet.
- **Full Load UPF Adjustment:** The potential coil is connected across rated supply voltage and rated full load current at unity power factor is passed through the current coil. The brake magnet position is adjusted to vary the braking torque so that the moving system moves at correct speed.
- **Lag or LPF adjustment:** The pressure coil is connected across the rated supply voltage and rated full load current at 0.5 lagging power factor is passed through the current coil. The lag device is adjusted until the meter runs at true speed.
- **Light Load UPF Adjustment:** Firstly, full load UPF and LPF adjustments are made on the meter until it runs at correct speed. Then rated supply voltage is applied across the pressure coil and a very low current of 5-10 % of full load value is passed through

the meter at unity power factor. The light load adjustment is done so that the meter runs at proper speed.

- **Creep Adjustment:** Firstly, full load UPF and light load adjustments are made for correct speeds at both the loads and the performance is rechecked at 0.5 power factor. Then, as a final check on all the above adjustments, the pressure coil is excited by 110 % of the rated voltage with zero load current. If the light load adjustment is proper, the meter should not creep under these conditions. If the error still persists, then all the above adjustments are carried out.

Testing of Energy Meters

The torque testing including the checking of actual resistance of an energy meter as well as the adjustment that are done to bring the error within a limit.

1. **Creep test:** With an applied voltage of 110% of the marked value of the current the load side is open ckted and the aluminum disc should not revolved more than 1 unit.
2. **Starting test:** At 0.5% of the marked value of the current and with normal voltage the meter should not start and run.
3. **AC meter testing:** The energy meter should not be tested under the following Conditions.
 - At 5% of the marked current at unity power factor.
 - At 100% and 125% of the marked current and unity power factor.
 - At intermediate load and unity power factor.
 - At marked current and 0.5 pf lagging

Short questions with answer:

1. **What are the different parts of 1 ϕ Induction type Energy meter?**

Ans- i) Driving system ii) Moving system iii) Breaking system iii) Recording system.

2. **What are the different types of compensation done in an Energy meter?**

Ans- i) Voltage compensation ii) Overload compensation iii) Temperature compensation.

3. **Why testing are necessary in an Energy meter?**

Ans- Testing is necessary in Energy meter to bring the error within a limit.

4. **What are the different types of adjustments done in an Energy meter?**

Ans- i) Primarily light load adjustment ii) Full load unity power factor adjustment iii) Low pf adjustment iv) Creep adjustment

Long type questions:

1. Explain with suitable diagram the working of a single phase induction type energy meter
2. Write a short note on testing of Energy meter.
3. With necessary diagram explain different parts of Energy meter.

CHAPTER :5 MEASUREMENT OF SPEED, FREQUENCY AND POWER FACTOR

Tachometers, types and working principles :

Tachometer:

- The tachometer use for measuring the rotational speed or angular velocity of the machine .
- It works on the principle of relative motion between the magnetic field and shaft of the coupled device. The relative motion induces the EMF in the coil which is placed between the constant magnetic field of the permanent magnet. The develops EMF is directly proportional to the speed of the shaft.
- Depends on the natures of the induced voltage the electrical tachometer is categorized into two types.
 - AC Tachometer Generator
 - DC Tachometer Generator

DC Tachometer Generator:

- The main parts of the DC tachometer generator are Permanent magnet, armature, commentator, brushes, variable resistor, and the moving coil voltmeter
- The DC tachometer works on the principle that when the closed conductor moves in the magnetic field, EMF induces in the conductor. The magnitude of the induce emf depends on the flux link with the conductor and the speed of the shaft.

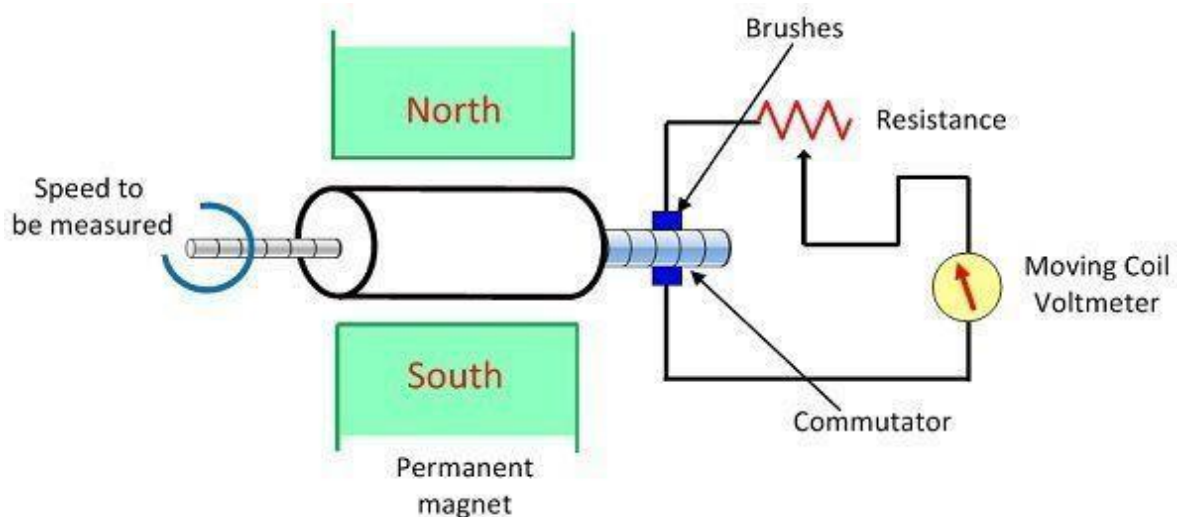

DC Tachometer Generator

- The armature of the DC generator revolves between the constant field of the permanent magnet. The rotation induces the emf in the coil. The magnitude of the induced emf is proportional to the shaft speed
- The commutator converts the alternating current of the armature coil to the direct current with the help of the brushes.
- The moving coil voltmeter measures the induced emf. The polarity of the induced voltage determines the direction of motion of the shaft.
- The resistance is connected in series with the voltmeter for controlling the heavy current of the armature.

The emf induced in the dc tachometer generator is given as

$$E = \frac{\Phi P N}{60} \times \frac{z}{a}$$

Where, E – generated voltage

Φ – flux per poles in Weber

P- number of poles

N – speed in revolution per minutes

Z – the number of the conductor in armature windings.

a – number of the parallel path in the armature windings.

$$E \propto N$$

$$E = KN$$

$$K = \text{Constant} = \frac{\Phi P}{60} \times \frac{z}{a}$$

Advantages of the DC Generator:

- The polarity of the induced voltages indicates the direction of rotation of the shaft.
- The conventional DC type voltmeter is used for measuring the induced voltage.

Disadvantages of DC Generator:

- The commutator and brushes require the periodic maintenance.
- The output resistance of the DC tachometer is kept high as compared to the input resistance. If the large current is induced in the armature conductor, the constant field of the permanent magnet will be distorted.

AC Tachometer Generator:

- The AC tachometer has stationary armature and rotating magnetic field. Thus, the commutator and brushes are absent in AC tachometer generator.
- The rotating magnetic field induces the EMF in the stationary coil of the stator. The amplitude and frequency of the induced emf are equivalent to the speed of the shaft.

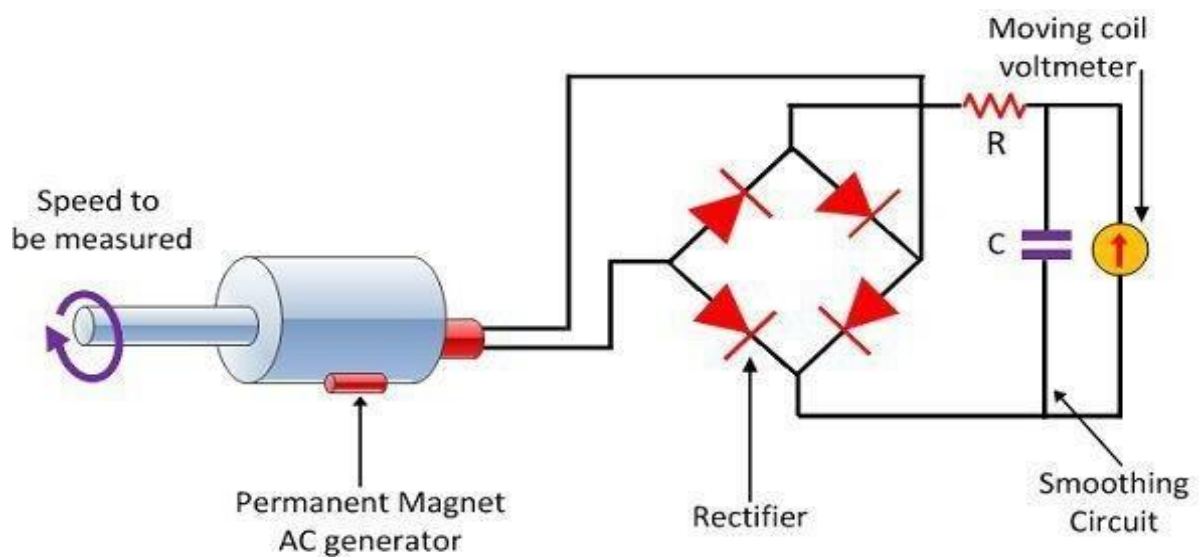

A.C Tachometer Generator

Circuit Globe

- The stator of the generator consists two windings, i.e., the reference and quadrature winding. Both the windings are mounted 90° apart from each other. The rotor of the tachometer is made with thin aluminium cup, and it is placed between the field structures.
- The rotor is made of the highly inductive material which has low inertia. The input is provided to the reference winding, and the output is obtained from the quadrature winding.
- The rotation of rotor between the magnetic field induces the voltage in the sensing winding. The induces voltage is proportional to the speed of the rotation.

Advantages:

- This Tachogenerator generates the ripple free output voltage.
- The cost of the generator is also very less.

Disadvantages:

- The nonlinear relationship obtains between the output voltage and input speed when the rotor rotates at high speed.

Principle of operation and construction of Mechanical and Electrical resonance Type frequency meters :

Frequency Meter :- These are used to measure supply frequency. These are used at generating stations & substations. A frequency meter is an instrument that displays the frequency of a periodic electrical signal.

Mechanical resonance Type frequency meters:

- A mechanical type frequency meter consists of a number of thin steel strips called reeds. These reeds are placed in a row alongside and close to an electromagnet.
- The electromagnet consists of thin laminations and a coil is wound around it as shown in fig. The coil is connected in series with a resistance across the supply whose frequency is to be measured.

Mechanical resonance type frequency meter

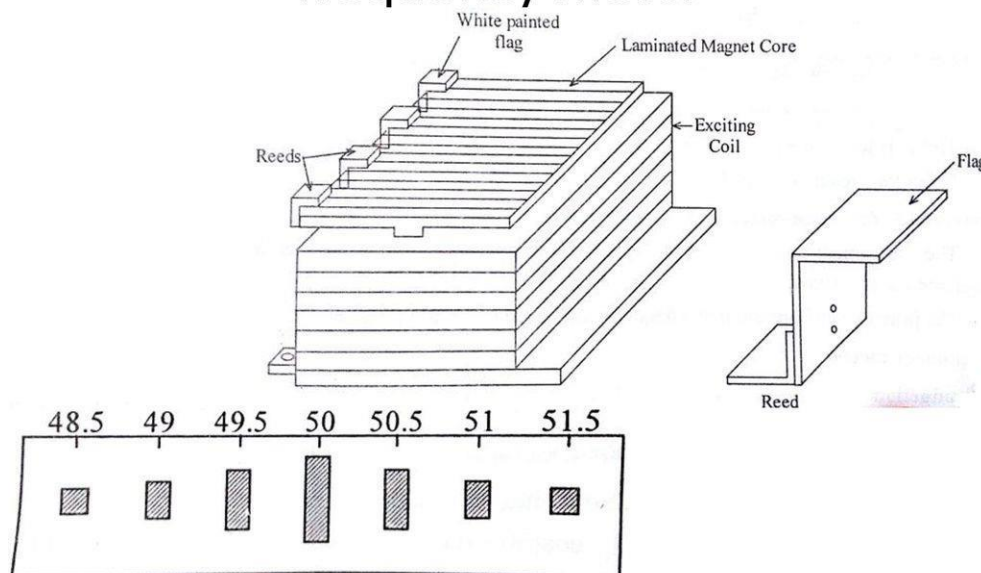

Mechanical Resonance Type Frequency Meter Working Principle:

- When mechanical resonance type frequency meter is connected across the supply whose frequency is to be measured an alternating current I flows through the coil of an electromagnet which produces a force of attraction on the reeds.

- The force of attraction is proportional to the square of the current therefore it varies at twice the supply frequency. Hence a force of exerted on the reeds at every half cycle.
- All the reeds thus tend to vibrate, but only the one whose natural frequency is double that of supply will vibrate appreciably.
- Mechanical resonance is obtained in the case of this reed. The frequency is determined, therefore by noting the scale reading opposite the reed that vibrates with maximum amplitude.
- The tuning in these meters is so sharp that as the excitation frequency changes from resonant frequency the amplitude of vibration decreases rapidly becoming negligible for a frequency which is slightly away from resonant one.

Advantages:

- Its indications are independent.
- Its readings are reliable.
- These are cheap.

Disadvantages:

- The reading is not be observed properly if the frequency difference is half cycle between the adjacent reeds.
- These instruments are not accurate to provide the exact reading on its scale

Electrical resonance Type frequency meters :

It is a type of frequency meter which is used to measure frequency range 45 Hz to 55 Hz of AC supply.

Construction :-

- It consists of a fixed coil which is connected across the supply whose frequency is to be measured. This coil is called magnetizing coil.
- The magnetizing coil is mounted on a laminated iron core. The iron core has a cross-section which varies gradually over the length, being maximum near the end where the magnetizing coil is mounted & minimum at the other end.
- A moving coil is pivoted over this iron core. A pointer is attached to the moving coil. The terminals of the moving coil are connected to a suitable capacitor C. There is no provision for a controlling force.

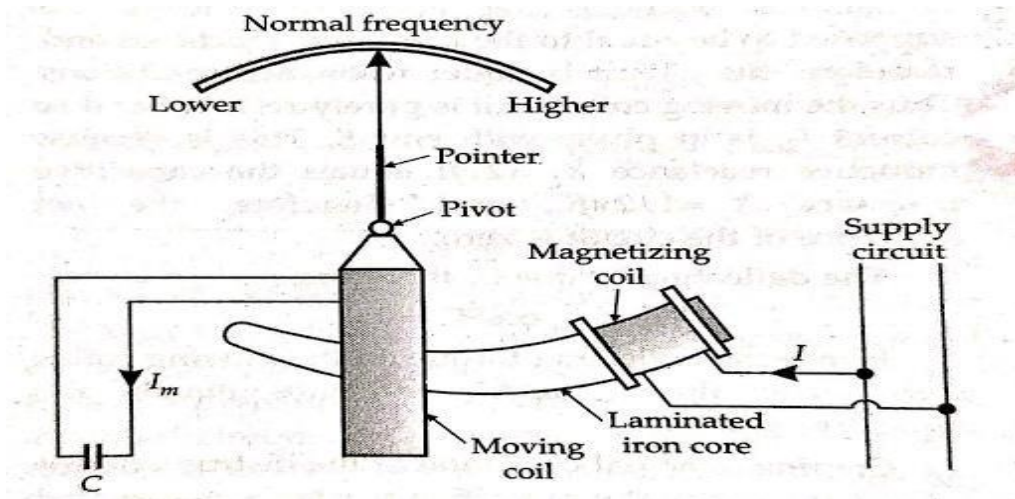

Working :-

- Due to the current in the moving coil, the moving coil produces a flux in phase with the current. This flux flows along with the extended core of the fixed coil,
- Therefore the flux links the moving coil. Hence, the flux induces an emf across the moving coil. Obviously, this induced emf lags the flux by 90° .
- Since it is a coil; the moving coil will have some inductive reactance. Again, as it is connected across a capacitor, it will have some capacitive reactance also.

Advantages:

- Highly sensitive
- Construction is simple
- The frequency scale is linear
- Readings are independent of voltages
- It is suitable for measuring a wide range of voltage.

Disadvantages:

- Sensitive to temperature variation
- The presence of rectifiers results in distortion producing inaccurate frequency output.

Principle of operation and working of Dynamometer type single phase and three phase power factor meters :

Definition: The power factor meter measures the power factor of a transmission system. The power factor is the cosine of the angle between the voltage and current. The power factor meter determines the types of load using on the line, and it also calculates the losses occur on it.

Single phase Dynamometer type Power factor meter:

- It consists of a fixed coil FF (split into two parts) which carries the current of the circuit under test. So, the magnetic field produced by this coil is proportional to the main current

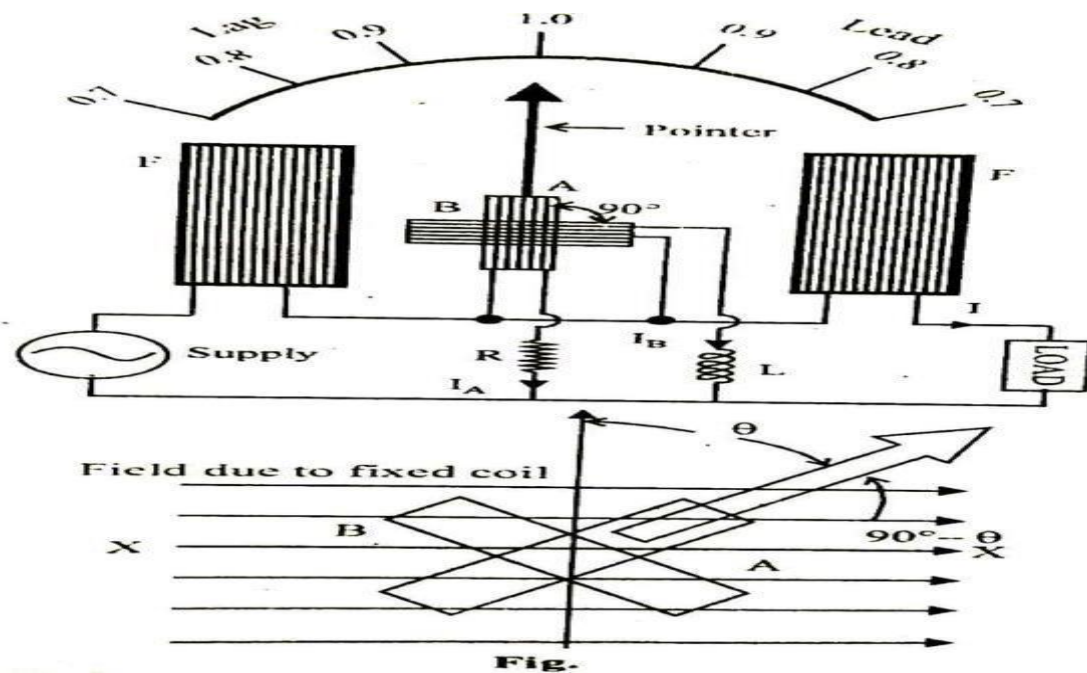
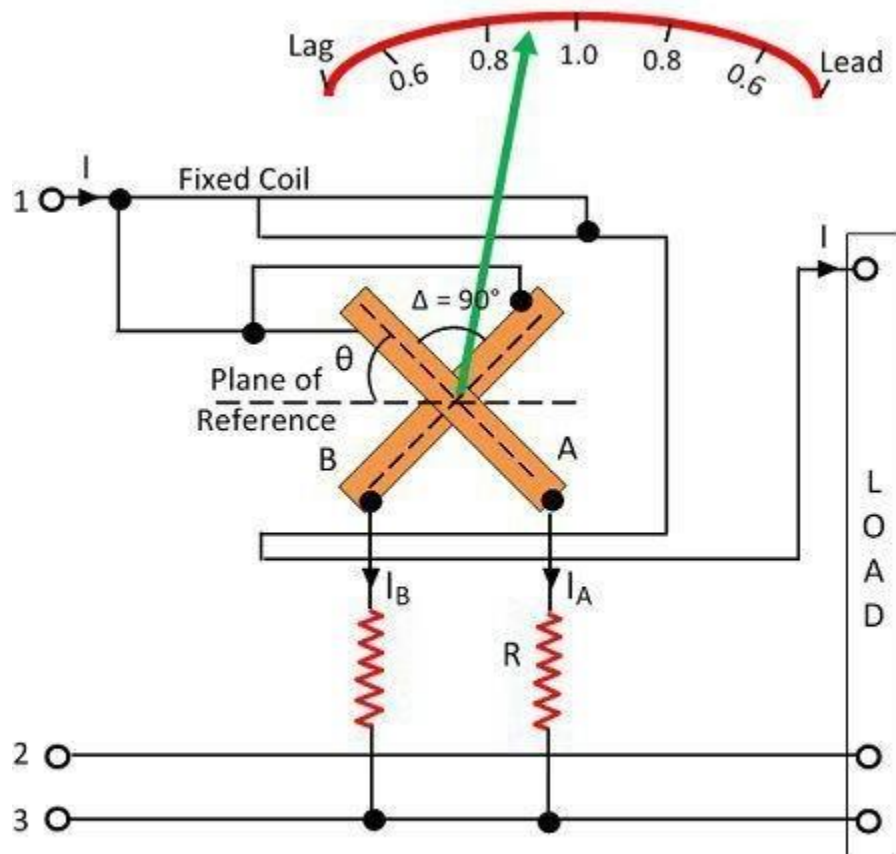

Fig.

- The identical pressure coils A and B pivoted on a spindle constitutes the moving system.
- Pressure coil A has a non-inductive resistance R which is connected in series with it, and coil B has a highly inductive choke coil L which is connected in series with it.
- The two coils are connected across the voltage of circuit. The value of R and L are so adjusted that the two coils carry the same value of current at normal frequency i.e. $R = \omega L$.
- The current through the coil A is in phase with the circuit voltage while that through the coil B lags the voltage by an angle which is nearly equal to 90° .
- The angle between the planes of coils is equal to δ .

Three phase Dynamo-meter type Power factor meter:

- The construction of the three phase meter is shown in the figure below. The electro-dynamometer is only useful for the balanced load. The moving coil is placed at an angle of 120° . They are connected across different phases of the supply circuit. Both the coil has a series resistance.



Three Phase Dynamo Type Factor Meter

Circuit Globe

- The voltage across the coil A is V_{12} and the current across it I_{A1} . The circuit of the coil is resistive, and hence the current and voltage are in phase with each other. Similarly, the voltage V_{13} and the current I_{B1} is in phase with each other.

Advantages of Electrodynamic Type Power Factor Meter:

1. Losses are less because of minimum use of iron parts and also give less error over a small range of frequency as compared to moving iron type instruments.
2. They high torque is to weight ratio.

Disadvantages of Electrodynamic Type Power Factor Meter:

1. Working forces are small as compared to moving iron type instruments.
2. The scale is not extended over 360° .
3. Calibration of electrodynamic type instruments are highly affected by the changing the supply voltage frequency.
4. They are quite costly as compared to other instruments.

Short questions with answer:

1. What is the use of tachometer ?

Ans:- A tachometer is an instrument measuring the rotation speed of a shaft or disk, as in a motor or other machine.

2. What are the advantages of d.c tachometer?

Ans-

- The polarity of the induced voltages indicates the direction of rotation of the shaft.
- The conventional DC type voltmeter is used for measuring the induced voltage.

3. What are the advantages and disadvantages of mechanical resonance type frequency meter?

Ans-

Advantages:

- Its indications are independent.
- Its readings are reliable.
- These are cheap.

Disadvantages:

- The reading is not observed properly if the frequency difference is half cycle between the adjacent reeds.
- These instruments are not accurate to provide the exact reading on its scale

Long type questions:

1. With neat sketch explain the working principle of an mechanical resonance type frequency meter?
2. Explain with diagram working of a 3-phase Dynamometer type P.F. meter?
3. Write short notes on Electrical Resonance frequency meter?
4. Explain construction & working principle of 1-phase Electro dynamo meter type P.F. meter?

Chapter 6 :MEASUREMENT OF RESISTANCE, INDUCTANCE & CAPACITANCE

Resistance: It is the property of material which oppose the flow of current through it. Its unit is ohm (Ω).

Classification of Resistance:

<u>Classification of Resistance:</u>		
low resistance range: $R < 1\Omega$	medium resistance range: $1 \leq R \leq 100K\Omega$	high resistance range: $R > 100K\Omega$

• Methods of Measurements:-:

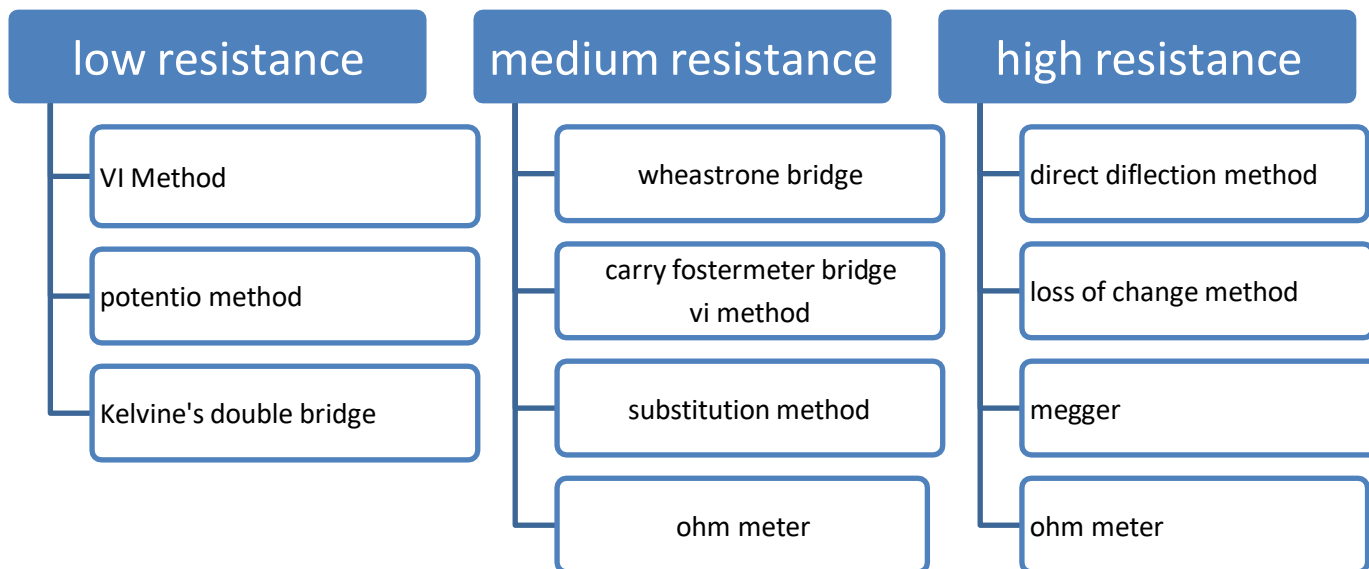

6.1..1.Measurement of low resistance by potentiometer method.

- The potentiometer method of measurement of resistance is used for measuring the unknown resistance of low value. This can be done by comparing the unknown resistance with the standard resistance.
- The R is the unknown resistance whose value is needed to be measured. The S is the standard resistance from which the value of unknown resistance is compared. The rheostat is used for controlling the magnitude of current into the circuit.

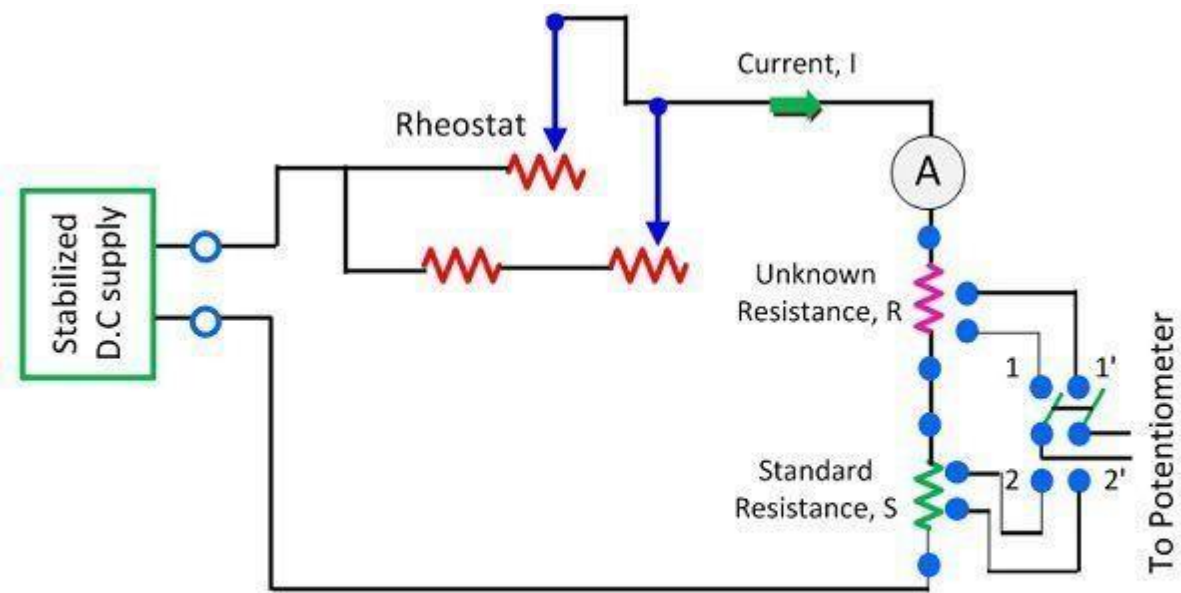

Measurement of Resistance with Potentiometer

Circuit Globe

- The double pole double throw switch is used in the circuit. The switch, when moves to position 1, 1 the unknown resistance connects to the circuit, and when it moves to position 2, 2 the standard resistance connects to the circuit.

Consider that when the switch is in position 1,1 the voltage drop across the unknown resistance is V_R

$$V_R = IR$$

and when it is in 2, 2 the voltage drop across the resistance is V_S

$$V_S = IS$$

On equating the equation (1) and (2), we get

$$\frac{V_R}{V_S} = \frac{IR}{IS}$$

$$\frac{V_R}{V_S} = \frac{R}{S}$$

$$R = \frac{V_R}{V_S} \cdot S$$

- The accuracy of unknown resistance depends on the value of standard resistance.

Example: In a measurement of resistance by potentiometer, the voltage drops across a resistor under test and across 0.024Ω standard resistor were found to be 0.885 V and 1.1 V resistivity. Determine the value of resistor under test.

Sol.

Given : $S=0.024 \Omega$, $V_x=0.885 \text{ V}$, $V_s=1.1 \text{ V}$

We know that $(X/S)=(V_x/V_s)$

$$X=(S*V_x)/V_s=(0.024*0.885)/1.1=0.0193 \Omega$$

6.1..2.Measurement of medium resistance by wheat Stone bridge method

The device uses for the measurement of minimum resistance with the help of comparison method is known as the Wheatstone bridge. The value of unknown resistance is determined by comparing it with the known resistance.

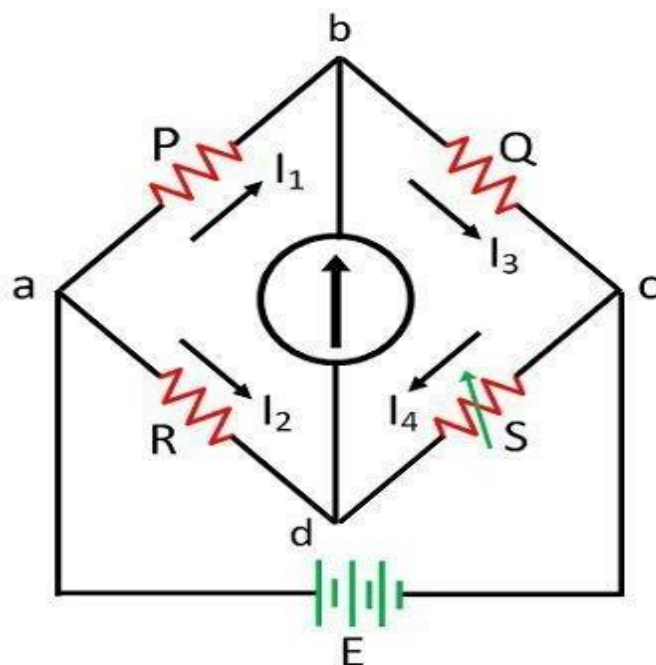

Wheatstone Bridge

The bridge is in balance condition when no current flows through the coil or the potential difference across the galvanometer is zero. This condition occurs when the potential difference across the a to b and a to d are equal, and the potential differences across the b to c and c to d remain same.

The current enters into the galvanometer divides into I_1 and I_2 , and their magnitude remains same. The following condition exists when the current through the galvanometer is zero.

$$I_1 P = I_2 R \dots \dots \dots \text{equ}(1)$$

The bridge in a balanced condition is expressed as

$$I_1 = I_3 = \frac{E}{P + Q}$$

$$I_2 = I_4 = \frac{E}{R + S}$$

Where E – emf of the battery.

By substituting the value of I_1 and I_2 in equation (1) we get.

$$\frac{PE}{P + Q} = \frac{RE}{R + S}$$

$$\frac{P}{P + Q} = \frac{R}{R + S}$$

$$P(R + S) = R(P + Q)$$

$$PR + PS = RP + RQ$$

$$PS = RQ \dots \dots \dots \text{equ}(2)$$

$$R = \frac{P}{Q} \times S \dots \dots \dots \text{equ}(3)$$

The equation (2) shows the balance condition of the Wheatstone bridge. The value of unknown resistance is determined by the help of the equation (3). The R is the unknown resistance, and the S is the standard arm of the bridge and the P and Q are the ratio arm of the bridge.

Example: A Wheatstone bridge consist of following parameter:

$R_1=20\text{ K } \Omega$, $R_2=30\text{ K } \Omega$, $R_3=80\text{ K } \Omega$

Determine the unknown resistance R_x

Sol:

Using the bridge balance Equation we had

$$R_1 * R_x = R_2 * R_3$$

$$R_x = (R_2 * R_3) / R_1$$

$$R_x = (30 * 80) / 20 = 120\text{K } \Omega$$

Measurement of high resistance by loss of charge method

- There are different methods that can be employed for the measurement of high resistances. Some of the important methods are as follows. i) Direct deflection method ii) Loss of charge method iii) Megohm bridge.

Loss of charge method :

- In loss of charge method unknown resistance is connected in parallel with capacitor and electrostatic voltmeter. The capacitor is initially charged to some suitable voltage by means of a battery of voltage V and then allowed to discharge through the resistance.
- The terminal voltage is observed during discharge and it is given by,

$$V = v \exp(-t/CR) \quad V/v = \exp(-t/CR)$$

Or insulation resistance is given by,

$$R = t / (C \ln V/v) = 0.4343 t / (C \log V/v)$$

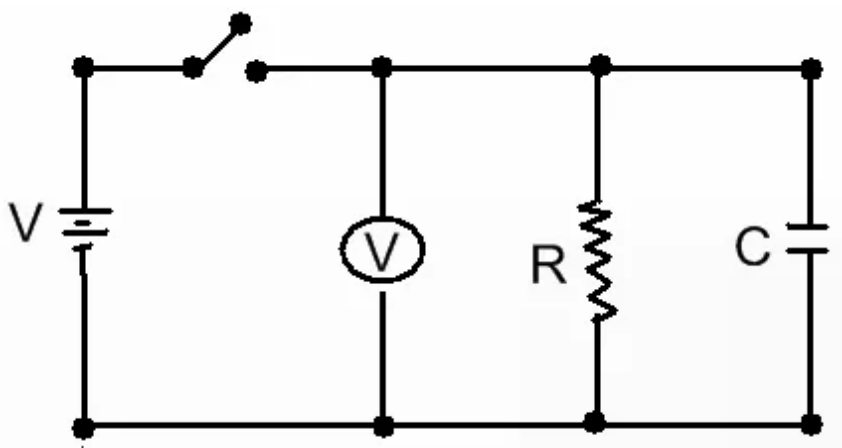

- From above equation it follows that if V, v, C and t are known the value of R can be computed. If the resistance R is very large the time for an appreciable fall in voltage is very large
- More accurate results may be obtained by change in the voltage V-v directly and calling this change as e, the expression for R becomes:

$$R = \frac{0.4343 t}{C \log_{10} \frac{V}{V-e}}$$

- This change in voltage may be measured by a galvanometer. This curve is linear as shown in second figure and thus determination of time t from this curve for the voltage to fall from V to v yields more accurate results.
- Loss of charge method is applicable to some high resistances, but it requires a capacitor of very high leakage resistance as high as resistance being measured.

Construction, principle of operations of Megger & Earth tester for insulation resistance and earth resistance measurement respectively.

Construction, principle of operations of Megger for measurement of insulation resistance:

Megger: An instrument that is used to measure insulation resistance is a Megger. It is also known as meg-ohm-meter.

Insulation Resistance: Insulation resistance is resistance in ohms of wires, cables, and electrical equipment, which is used to safeguard the electrical systems like electrical motors from any accidental damages like electrical shocks or sudden discharges of current leakages in wire.

Principle of Megger: The principle of Megger is based on moving coil in the instrument. When current is flowing in a conductor, which is placed in a magnetic field, it experiences a torque.

Where vectored Force = strength and direction of the current and magnetic field.

Case (i) Resistance of insulation = High; pointer of moving coil = infinity,

Case (ii) Resistance of insulation = Low; pointer of moving coil = zero.

Megger is used to measure a high value of resistance. Megger consists of the following parts.

- DC generator
- 2 Coils (Coil A, Coil B)
- Clutch
- Crank handle
- terminal X & Y

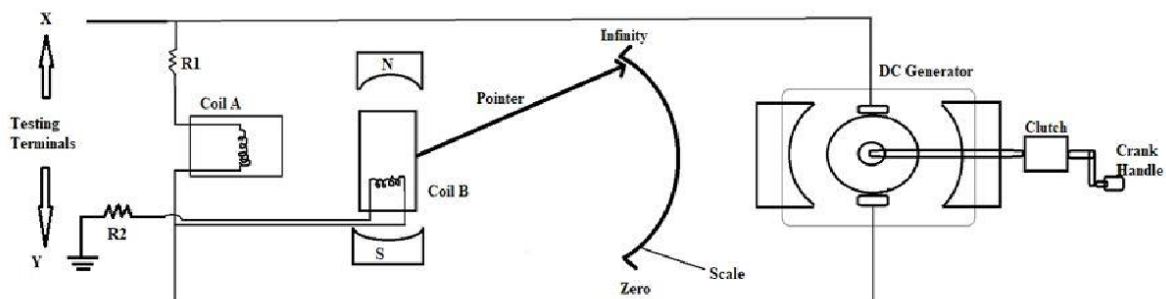

Block Diagram of Megger

- Crank handle present here is rotated manually, and the clutch is used to vary the speed. This arrangement placed between magnets, where the entire set-up is called a DC generator.
- A Resistance scale is present towards the left of the DC generator, which provides the value of resistance ranging from 0 to infinity.
- There are two coils in the circuit Coil-A and Coil-B, which are connected to the DC generator.

The two testing terminals X and Y which can be connected in the following manner

- To calculate the resistance of the winding of the transformer, then the transformer is connected between the two testing terminals X and Y.
- If we want to measure the insulation of the cable, then the cable is connected between the two testing terminals A and B.

Working of Megger

Megger here is used to measure

- Insulation resistance
- Machine windings

According to the principle of DC generator, whenever a current-carrying conductor is placed between the magnet fields, it induces a certain amount of voltage. The magnetic field generated between the two poles of the permanent magnet is used to rotate the rotor of the DC generator using the crank handle.

Whenever we rotate this DC rotor, some voltage and current are generated. This current flows through the Coil A and Coil B in an anti-clockwise direction.

Where coil A carries current = I_A and

Coil B carries current = I_B .

These two current produces fluxes ϕ_A and ϕ_B in two coils A and B.

- On one side motor requires two fluxes to interact and produce reflecting torque, then the only motor runs.
- Whereas on the other side the two flux's ϕ_A and ϕ_B which are interacted with each other and then the pointer which is presented will experience some force by the production of deflecting torque " T_d ", where the pointer shows the resistance value on the scale.

Pointer:

- The pointer on the scale initially indicates infinity value,
- Where ever it experiences a torque, the pointer moves from infinity position to zero position on the resistance scale.

Construction, principle of operations of Earth tester for earth resistance measurement:

The instrument used for measuring the resistance of the earth is known as earth tester.

Construction of Earth Tester:

The earth tester uses as hand driven generator. The rotational current reverser and the rectifier are the two main parts of the earth tester. The current reverser and the rectifier are mounted on the shaft of the DC generator. The earth tester works only on the DC because of the rectifier.

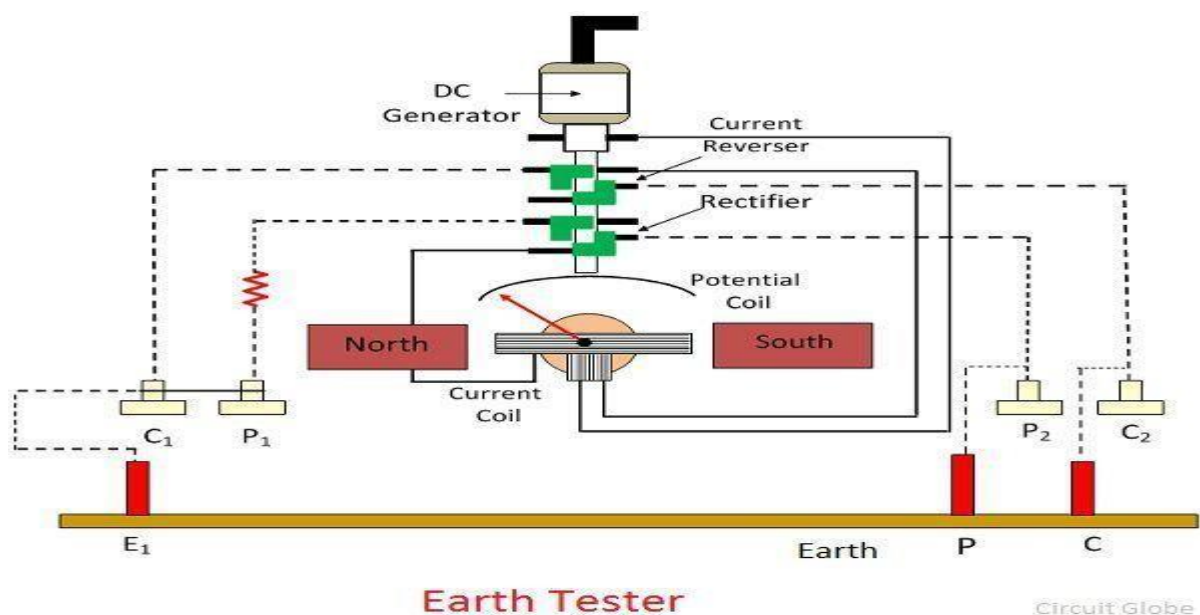

- The tester has two commutators place along with the current reverser and rectifier. The each commutator consist four fixed brushes. The commutator is a device used for converting the direction of flows of current. It is connected in series with the armature of the generator. And the brushes are used for transferring the power from the stationary parts to the moving parts of the devices.

- The arrangement of the brushes can be done in such a way that they are alternately connected with one of the segments even after the rotation of the commutator. The brushes and the commutators are always connected to each other.
- The earth tester consists two pressures and the current coils. The each coil has two terminals. The pair of the pressure coil and the current coil are placed across the permanent magnet. The one pair of current and pressure coil is short-circuited, and it is connected to the auxiliary electrodes.
- The one end terminal of the pressure coil is connected to the rectifier, and their other end is connected to the earth electrode. Similarly, the current coil is connected to the rectifier and earth electrode.
- The earth tester consists the potential coil which is directly connected to the DC generator. The potential coil is placed between the permanent magnet. The coil is connected to the pointer, and the pointer is fixed on the calibrated scale. The pointer indicates the magnitude of the earth resistance. The deflection of the pointer depends on the ratio of the voltage of pressure coil to the current of the current coil.
- The short-circuit current passes through the equipment to the earth is alternating in nature. Thus, we can say that the alternating current flows in the soil. This alternative current reduces the unwanted effect of the soil, which occurs because of chemical action or because of the production of back emf.

Construction and principles of Multimeter. (Analog and Digital)

ANALOG MULTIMETER:-

- The main part of an analog multi meter is the D'Arsonval meter movement also known as the permanent-magnet moving-coil (PMMC) movement. This common type of movement is used for dc measurements.

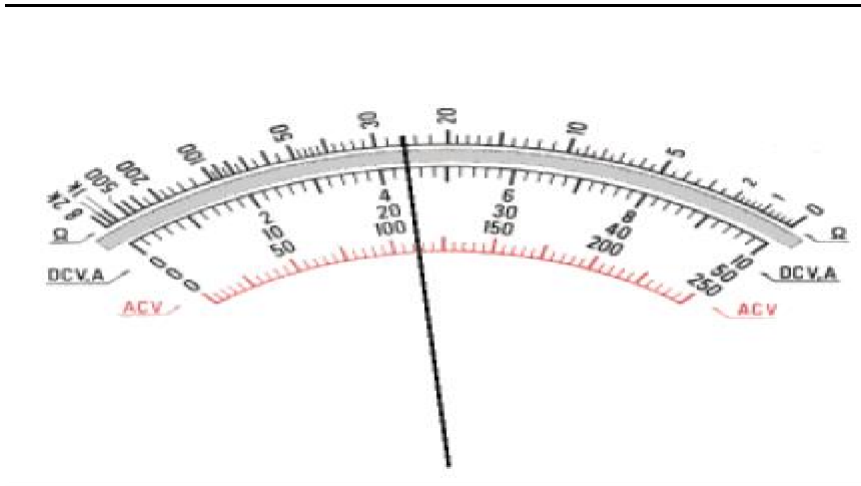
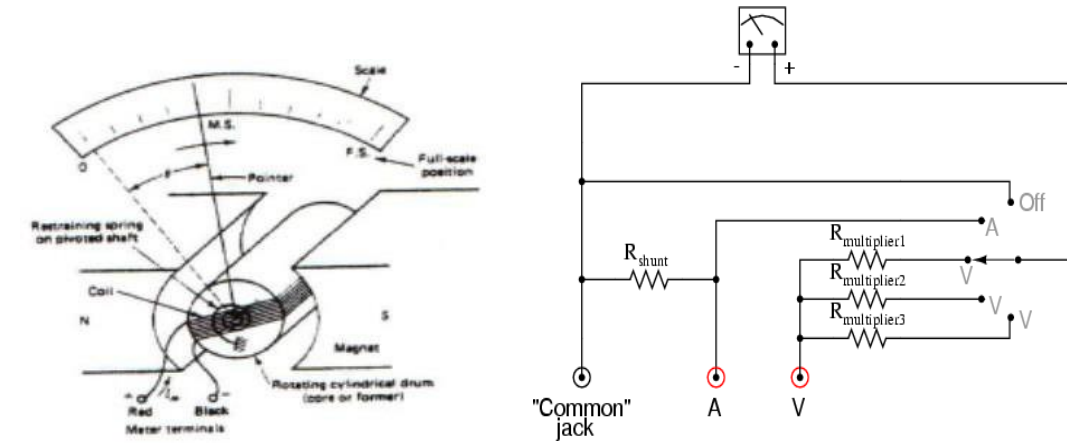

- When the meter current I_m flows in the wire coil in the direction indicated in figure a magnetic field is produced in the coil .This electrically induced magnetic field interacts with the magnetic field of the horseshoe-type permanent magnet.
- The result of such an interaction is a force causing a mechanical torque to be exerted on the coil. Since the coil is wound and permanently fixed on a rotating cylindrical drum as shown, the torque produced will cause the rotation of the drum around its pivoted shaft.
- When the drum rotates, two restraining springs, one mounted in the front onto the shaft and the other mounted onto the back part of the shaft, will exhibit a counter torque opposing the rotation and restraining the motion of the drum.
- This spring-produced counter-torque depends on the angle of deflection of the drum, θ or the pointer. At a certain position (or deflection angle), the two torques are in equilibrium. Each meter movement is characterized by two electrical quantities
 - a) R_m : the meter resistance which is due to the wire used to construct the coil
 - b) I_{FS} : the meter current which causes the pointer to deflect all the way up to the fullscale position on the fixed scale.

- This value of the meter current is always referred to as the full scale current of the meter movement. The PMMC movement cannot be used directly for ac measurements since the inertia of PMMC acts as an averager.
- Since ac current has zero average value and it produces a torque that has also zero average value, the pointer just vibrates around zero on the scale.
- In order to make ac measurements, a bridge rectifier circuit is combined with PMMC as shown in figure below.

DIGITAL MULTIMETER

A Digital multimeter offers increased versatility due to its additional capability to measure A.C voltage and current, D.C voltage and current, resistance. The FIG. Shows the block diagram of a digital multimeter (DMM)

In the "A.C voltage mode", the applied input is fed through a calibrated/ compensated attenuator, to a precision full-wave rectifier circuit followed by a ripple reduction filter. The resulting D.C is fed to ADC and the subsequent display system.

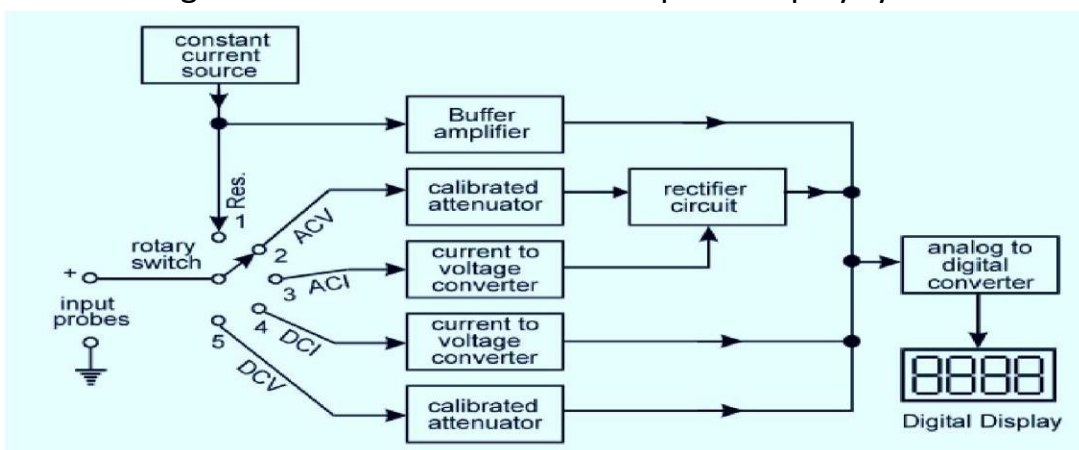

For current measurements the drop across an internal calibrated shunt is measured ,directly By the ADC in the “D.C current mode” , and after A.C to D. C conversion in the “ A.C current mode”. This drop is often in the range of 200 mv.

Due to lack of precision in the A.C –D.C conversions, the accuracy in the A.C range is in general of the order of 0.2 to 0.5%. In addition , the measurement range is often limited to about 50 Hz at the lower frequency end due to the ripple in the rectified signal becoming a non negligible percentage of the display and hence in fluctuation of the displayed number.

In the resistance range the multimeter operates by measuring the voltage across the externally connected resistance ,resulting from a current forced through it from a calibrated internal current source.

The accuracy of resistance measurement is of the order of 0.1 to 0.5% depending on the accuracy and stability of the internal current sources the accuracy may be proper in the highest range which is often about 10 to 20 M Ω . In the lowest range the full scale may be 200 Ω with a resolution of about 0.01 Ω for a digital multimeter.

Measurement of Inductance by Maxwell’s bridge method :

The bridge used for the measurement of self-inductance of the circuit is known as the Maxwell bridge. It is the advanced form of the Wheatstone bridge. In such type of bridges, the value of unknown resistance is determined by comparing it with the known value of the standard self-inductance. The connection diagram for the balance Maxwell bridge is shown in the figure below

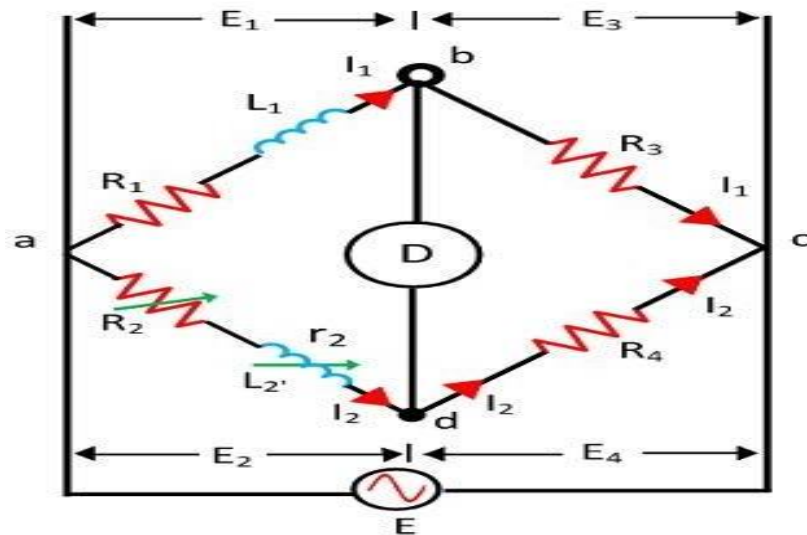

Maxwell's Inductance Bridge

Circuit Globe

Let, L_1 – unknown inductance of resistance R_1 .

L_2 – Variable inductance of fixed resistance r_1 .

R_2 – variable resistance connected in series with inductor L_2 .

R_3, R_4 – known non-inductance resistance

At balance,

$$L_1 = \frac{R_3}{R_4} L_2$$

$$R_1 = \frac{R_3}{R_4} (R_2 + r_2)$$

Advantages of the Maxwell's Bridges

1. The balance equation of the circuit is free from frequency.
2. Both the balance equations are independent of each other.
3. The Maxwell's inductor capacitance bridge is used for the measurement of the high range inductance.

Disadvantages of the Maxwell's Bridge

1. The Maxwell inductor capacitance bridge requires a variable capacitor which is very expensive. Thus, sometimes the standard variable capacitor is used in the bridges.
2. The bridge is only used for the measurement of medium quality coils.

Measurement of capacitance by Schering's Bridge method:

The Schering bridge use for measuring the capacitance of the capacitor, dissipation factor, properties of an insulator, capacitor bushing, insulating oil and other insulating materials. It is one of the most commonly used AC bridge. The Schering bridge works on the principle of balancing the load on its arm.

Let, C_1 – capacitor whose capacitance is to be determined,

r_1 – a series resistance, representing the loss of the capacitor C_1 .

C_2 – a standard capacitor (The term standard capacitor means the capacitor is free from loss)

R_3 – a non-inductive resistance

C_4 – a variable capacitor.

R_4 – a variable non-inductive resistance parallel with variable capacitor C_4 .

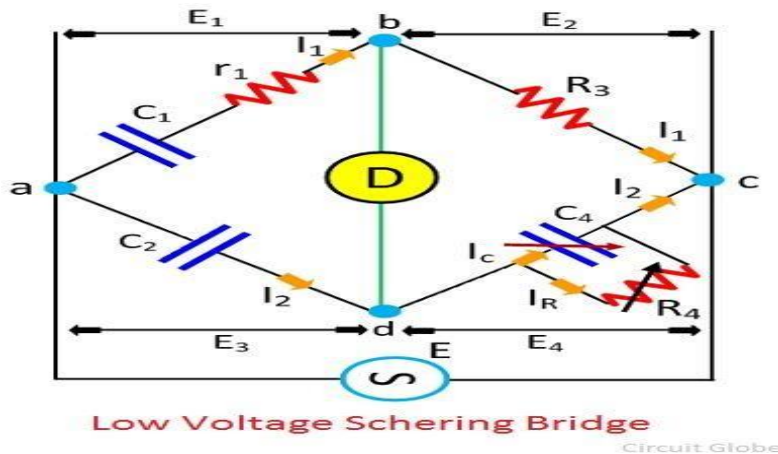

When the bridge is in the balanced condition, zero current passes through the detector, which shows that the potential across the detector is zero. At balance condition

$$Z_1/Z_2 = Z_3/Z_4$$

$$Z_1Z_4 = Z_2Z_3$$

$$\left(r_1 + \frac{1}{j\omega C_1}\right) \left(\frac{R_4}{1 + j\omega C_4 R_4}\right) = \frac{1}{j\omega C_2} \cdot R_3$$

$$\left(r_1 + \frac{1}{j\omega C_1}\right) R_4 = \frac{R_3}{j\omega C_2} (1 + j\omega C_4 R_4)$$

$$r_1 R_4 - \frac{j R_4}{\omega C_1} = -j \frac{R_3}{\omega C_2} + \frac{R_3 R_4 C_4}{C_2}$$

So, Equating the real and imaginary equations, we get

$$r_1 = \frac{R_3 C_4}{C_2} \dots \dots \dots equ(1)$$

$$C_1 = C_2 \left(\frac{R_4}{R_3} \right) \dots \dots \dots equ(2)$$

The equation (1) and (2) are the balanced equation, and it is free from the frequency.

Short Questions with Answer:

1) Define Resistance? Also write down types of resistance?

Ans- Resistance: It is the property of material which oppose the flow of current through it. Its unit is ohm (Ω).

Types of resistance:

<u>Classification of Resistance:</u>		
low resistance range: $R < 1\Omega$	medium resistance range: $1 \leq R \leq 100K\Omega$	high resistance range: $R > 100K\Omega$

2) What are the method used for measurement of low resistance?

- Ans-i)** Potentiometer
 ii) V-I method
 iii) Kelvin' double bridge method

3) Which bridge is used for the measurement of inductance?

Ans- Maxwell' bridge

4) Which bridge is used for the measurement of capacitance?

Ans- Schering Bridge

5) What are the method used for the measurement of high resistance?

- Ans-i)** Loss of charge method
 ii) Direct deflection method
 iii) Megger method
 iv) Mega ohm bridge method

6) What is the use of earthing?

Ans-The purpose of earthing is to protect various parts of the installation system as well as the person working against damage in case the insulation system fails at any point of time

Long Questions:

- 1) How to measure low resistance by potentiometer method?
- 2) Determine the value of unknown resistance by with the help of Wheatstone bridge method?
- 3) Write a short note on Megger?
- 4) Explain measurement of capacitance by Schering bridge and derive the equation?
- 5) Write a short note on
 - i) Digital multimeter
 - ii) Analog multimeter
- 6) Write down the difference between Analog multimeter and digital multimeter?

Chapter:7: SENSORS AND TRANSDUCER

Define Transducer, sensing element or detector element and transduction elements.

Transducer: The device which converts the one form of energy into another is known as the transducer. The process of conversion is known as transduction.



The transducer consists two important parts.

1. Sensing Element
2. Transduction Element

Sensing or Detector Element – It is the part of the transducers which give the response to the physical sensation. The response of the sensing element depends on the physical phenomenon.

Transduction Element – The transduction element converts the output of the sensing element into an electrical signal. This element is also called the secondary transducer.

7.2.Classification of transducer.

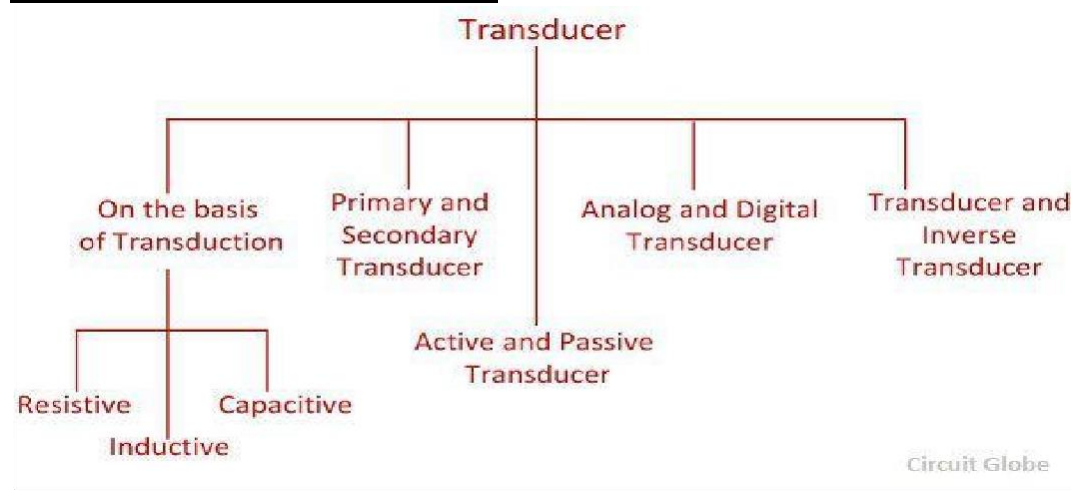

Resistive transducer:

The **transducer** whose **resistance varies** because of the **environmental effects** such type of transducer is known as the resistive transducer.

Working Principle of Resistive Transducer

The resistive transducer element works on the principle that the resistance of the element is directly proportional to the length of the conductor and

inversely proportional to the area of the conductor.

Where R – resistance in ohms.

A – cross-section area of the conductor in meter square.

L – Length of the conductor in meter square.

ρ – the resistivity of the conductor in materials in ohm meter.

Applications of Resistive Transducer

1. Potentiometer .

2. Strain gauges
3. Resistance Thermometer
4. Thermistor.

Linear and angular motion potentiometer.

The potentiometer is the three terminal device used for measuring the potential differences by manually varying the resistances.



Potentiometer Types

There are two main types of potentiometers:

- Angular motion potentiometer
- Linear potentiometer

Angular motion potentiometer(Rotary Potentiometer)

- The best example of a rotary potentiometer is the volume controller available in stereo and other music playing devices where the rotating knob is used to control the supply to the speaker. The Rotary potentiometer can deliver adjustable supply voltage to the electrical and electronic circuits.

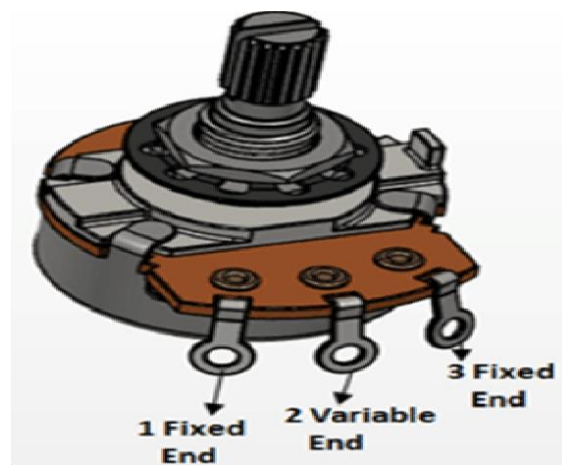

- The Rotary POT consists of two terminal contacts (pin 1 and 3) with uniform resistance, it is placed in the shape of a semi-circle and the middle terminal (pin 2) is connected to the resistance through a sliding contact called wiper which is attached with a rotating knob.
- The knob is rotated to move the sliding contact across the resistance which in turn varies the resistance of the POT. The output is taken between one of the terminals of the semicircle and the terminal attached to the sliding contact.

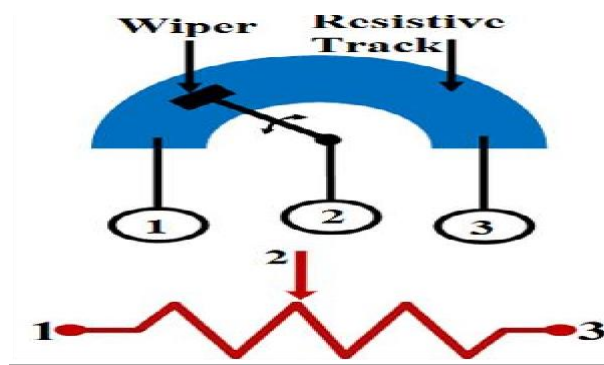

Linear Potentiometers

- The linear potentiometer is basically the same but the only difference is that here instead of rotary movement the sliding contact gets moved on the resistor linearly. Here two ends of a straight resistor are connected across the source voltage.
- A sliding contact can be slide on the resistor through a track attached along with the resistor. The terminal connected to the sliding is connected to one end of the output circuit and one of the terminals of the resistor is connected to the other end of the output circuit.



- This type of potentiometer is mainly used to measure the voltage across a branch of a circuit, for measuring the internal resistance of a battery cell, for comparing a battery cell with a standard cell and in our daily life, it is commonly used in the equalizer of music and sound mixing systems.

Advantages of Potentiometers

- Higher reliability
- Increased accuracy
- Small size, multiple potentiometers can be packed on a single chip
- Negligible resistance drift
- Unaffected by environmental conditions like vibrations, humidity, shocks and wiper contamination
- No moving part
- Tolerance up to $\pm 1\%$
- Very low power dissipation, up to tens of milliwatts

Disadvantages of Potentiometers

- Not suitable for high temperature environment and high power application.
- Due to the parasitic capacitance of the electronic switches, there is a bandwidth consideration that comes into the picture in digital potentiometers. It is the maximum signal frequency that can cross the resistance terminals with less than 3 dB attenuation in the wiper. The transfer equation is similar to that of a low pass filter.
- The nonlinearity in the wiper resistance adds a harmonic distortion to the output signal. The total harmonic distortion, or THD, quantifies the degree to which the signal is degraded after crossing through the resistance.

Applications of Potentiometer

1. Comparing the emf of a battery cell with a standard cell
2. Measuring the internal resistance of a battery cell
3. Measuring the voltage across a branch of a circuit

Thermistor and Resistance thermometers:

Thermistor:

- A thermistor (or thermal resistor) is defined as a type of resistor whose electrical resistance varies with changes in temperature. Thermistors act as a passive component in a circuit. They are an accurate, cheap, and robust way to measure temperature. The circuit symbol for a thermistor is shown below:

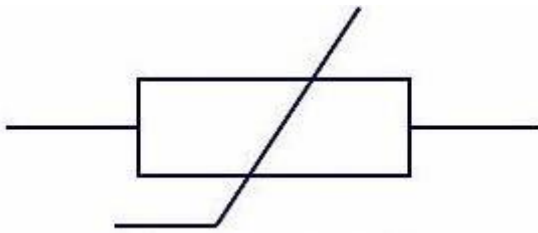

Working Principle:

- The working principle of a thermistor is that its resistance is dependent on its temperature. We can measure the resistance of a thermistor using an ohmmeter.
- If we know the exact relationship between how changes in the temperature will affect the resistance of the thermistor – then by measuring the thermistor's resistance we can derive its temperature.
- How much the resistance changes depends on the type of material used in the thermistor. The relationship between a thermistor's temperature and resistance is non-linear. A typical thermistor graph is shown below:

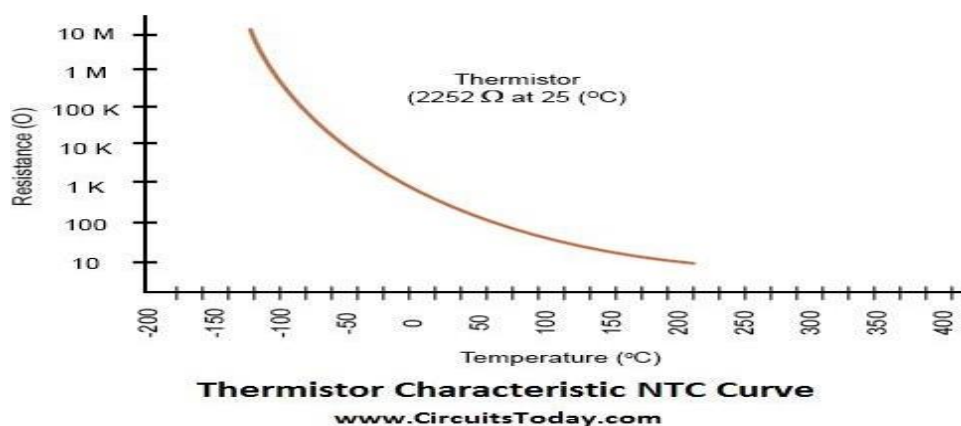

- If we had a thermistor with the above temperature graph, we could simply line up the resistance measured by the ohmmeter with the temperature indicated on the graph.
- By drawing a horizontal line across from the resistance on the y-axis, and drawing a vertical line down from where this horizontal line intersects with the graph, we can hence derive the temperature of the thermistor.

Uses of Thermistors

- Digital thermometers (thermostats)
- Automotive applications (to measure oil and coolant temperatures in cars & trucks)
- Household appliances (like microwaves, fridges, and ovens)
- Circuit protection
- Rechargeable batteries (ensure the correct battery temperature is maintained)
- To measure the thermal conductivity of electrical materials
- Useful in many basic electronic circuits (e.g. as part of a beginner Arduino starter kit)
- Temperature compensation (i.e. maintain resistance to compensate for effects caused by changes in temperature in another part of the circuit)
- Used in wheatstone bridge circuits.

Resistance thermometers:

- The resistance thermometer or resistance temperature detector (RTD) uses the resistance of electrical conductor for measuring the temperature.
- The resistance thermometer uses a sensitive element made of extremely pure metals like platinum, copper or nickel. The resistance of the metal is directly proportional to the temperature. Mostly, platinum is used in resistance thermometer. The platinum has high stability, and it can withstand high temperature. Gold and silver are not used for RTD because they have low resistivity.
- The resistance versus temperature curve is shown in the figure below. The curves are nearly linear, and for small temperature range, it is very evident.

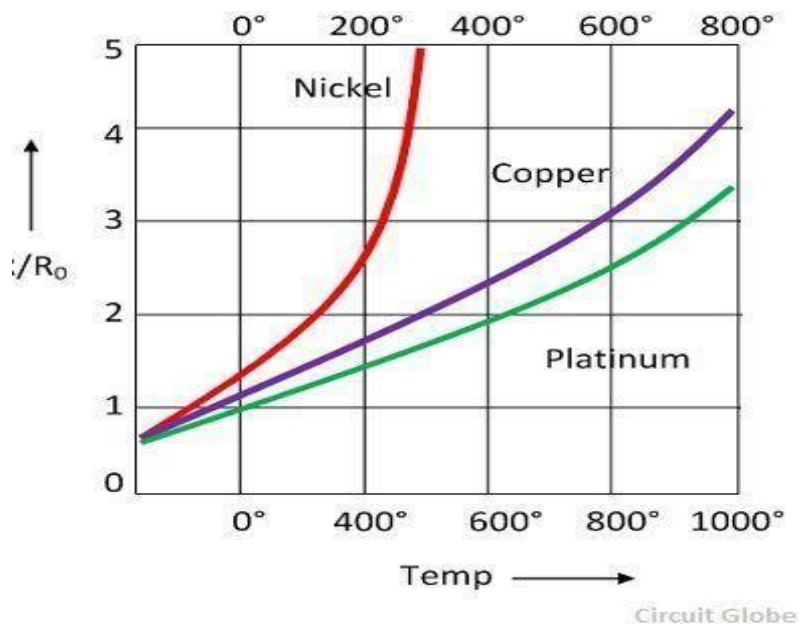

Construction of Resistive Thermometer:

- The resistance thermometer is placed inside the protective tube for providing the protection against damage. The resistive element is formed by placing the platinum wire on the ceramic bobbin. This resistance element is placed inside the tube which is made up of stainless steel or copper steel.

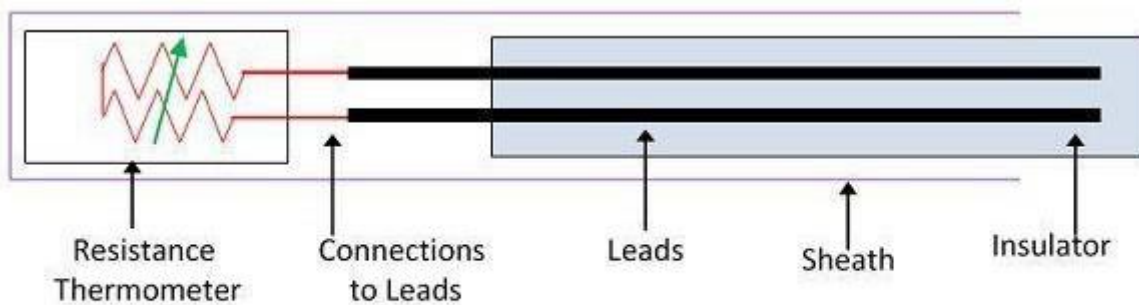

Resistance Thermometer

Circuit Globe

- The lead wire is used for connecting the resistance element with the external lead. The lead wire is covered by the insulated tube which protects it from short circuit. The ceramic material is used as an insulator for high-temperature material and for low-temperature fibre or glass is used.

Operation of Resistance Thermometer

- The tip of the resistance thermometer is placed near the measurand heat source. The heat is uniformly distributed across the resistive element. The changes in the resistance vary the temperature of the element. The final resistance is measured. The below mention equations measure the variation in temperature.

$$R_0(1 + \alpha_1 T + \alpha_2 T^2 + \dots + \alpha_n T^n + \dots) \dots \dots \text{equ}(1)$$

Where, R_0 – resistance at temperature $T = 0$ and $\alpha_1, \alpha_2, \alpha_3, \dots, \alpha_n$ are constants.

Linear Approximation

- The linear approximation is the way of estimating the resistance versus temperature curve in the form of the linear equation.

$$R_\theta = R_{\theta_0}(1 + \alpha_{\theta_0} \Delta\theta)$$

where R_θ – approximation resistance at $\theta^\circ\text{C}$

R_{θ_0} – approximation resistance at $\theta_0^\circ\text{C}$

$\Delta\theta = \theta - \theta_0$ change in temperature $^\circ\text{C}$ and the α_{θ_0} – resistance temperature coefficient at $\theta_0^\circ\text{C}$

Quadratic Approximation

- The quadratic approximation gives the accurate approximation of the resistance temperature curve. The approximation is expressed in the form of the quadratic equation

$$R_\theta = R_{\theta_0}[1 + \alpha_1 \Delta\theta + \alpha_2 (\Delta\theta)^2]$$

α_1 – linear fractional change in resistance

α_2 – quadratic function change in resistance.

- The resistance thermometer is very less sensitive, and the metal used for making the resistive element is less expensive.

Wire Resistance Strain Gauges:

A strain gauge is a passive transducer, that converts mechanical displacement into the change of resistance. A strain gauge sensor is a thin wafer-like device that can be attached to a variety of materials to measure applied strain. These are used as a fundamental sensor in many types of sensors like pressure sensors, load cells, torque sensors etc.

Strain Gauge Working Principle: The foil type strain gauges (Figure #1) are very common in which a resistive foil is mounted on a backing material. These are available in a variety of shapes and sizes for different applications. The resistance of the foil changes as the material to which the gauge is attached undergoes tension or compression due to change in its length and diameter. This change in resistance is proportional to the applied strain. As this change in resistance is very small in magnitude so its effect can be only sensed by a Wheatstone bridge. This is the basic strain gauge working principle.

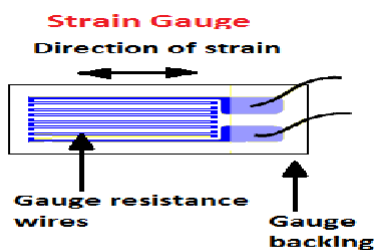

Figure #1

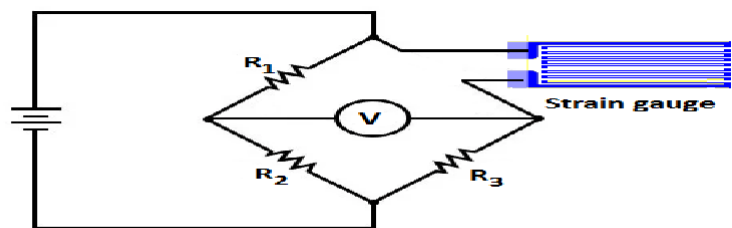

Figure #2

A circuit diagram is shown in Figure #2. In this circuit diagram, a strain gauge is connected into a Wheatstone bridge. This circuit is so designed that when no force is applied to the strain gauge, R_1 is equal to R_2 and the resistance of the strain gauge is equal to R_3 . In this condition the Wheatstone bridge is balanced and the voltmeter shows no deflection.

But when strain is applied to the strain gauge, the resistance of the strain gauge sensor changes, the Wheatstone bridge becomes unbalanced, a current flows through the voltmeter. Since the net change in the resistance is proportional to the applied strain, therefore, resultant current flow through the voltmeter is proportional to the applied strain. So, the voltmeter can be calibrated in terms of strain or force.

In the above circuit, we have used only one strain gauge. This is known as 'quarter bridge' circuit. We can also use two strain gauges or even four strain gauges in this circuit. Then this circuit is called 'half bridge' and 'full bridge'

respectively. The full bridge circuit provides greater sensitivity and least temperature variation errors.

Gauge Factor of Strain Gauge : The **gauge factor of strain gauge** is defined as the unit change in resistance per unit change in length.

i.e. gauge factor $G_f = (\Delta R/R)/(\Delta l/l)$

where, R = nominal gauge resistance,

ΔR = change in resistance,

l = length of the specimen in an unstressed condition,

Δl = change in specimen length.

Application: Some of the applications of strain gauges include –

- Rail monitoring
- Cable bridges
- Aerospace
- Nuclear power plants

Inductive Transducer:

An inductive transducer works on the basic principle of change in inductance due to any change in the measurand. A change in measurand changes the flux and this change in flux changes the inductance. This change in inductance can be calibrated in terms of measurand.

Inductive transducers works on one of the following principles

- **Change of self inductance**
- **Change of mutual inductance**
- **Production of eddy current**

Change of self inductance:

The self inductance of a coil is given by

$$L = N^2/R$$

Where N is the number of turns and R is the reluctance of the magnetic circuit. Also, the reluctance R is given by,

$$R = l/\mu A$$

Then,

$$L = N^2 \mu A/l$$

Where μ is the effective permeability of the medium, l is the length of the coil and A is the cross-sectional area of the coil.

Let $G=A/l$, known as geometric form factor. Therefore

$$L = N^2 \mu G$$

That is, the self-inductance can be changed by a variation in N , G or μ . If some physical

quantity is able to change any of these parameters, then that quantity can be directly measured in terms of inductance.

Change of mutual inductance:

Mutually coupled multiple coils are used in this principle. The mutual inductance can be then changed by varying the self-inductance of the coils.

Let's take two coils and suppose their self-inductance are L_1 and L_2 . Then mutual inductance between these two coils is given by,

$$M = \sqrt{L_1 L_2}$$

Where K is the coefficient of coupling.

It is clear that the mutual inductance can be changed if the self-inductance of the coils or the coefficient of coupling is varied. The coefficient of coupling depends on distance, separation and orientation between these two coils.

To measure displacement, one coil is fixed and the other coil is connected to the moving object. The coefficient of coupling changes with varying distance and hence the mutual inductance also changes. This change in mutual inductance can be calibrated in terms of displacement.

Production of Eddy current:

When a coil is placed near to a coil carrying alternating current (AC), a circulating current called **Eddy current** is induced in the coil. This circulating current produces its own flux and tries to reduce the flux of the coil carrying the current which in turn changes the inductance of the coil.

When the coils are nearer, the eddy current produced is higher and the reduction in inductance also increases. So inductance can be varied by a variation of distance between two coils.

Advantages:

- Inductive transducers can withstand adverse environmental conditions like temperature, humidity, etc. It can perform in an industrial environment.
- This transducer has good accuracy and is considered to be stable in operation with a good life span.
- It can be subjected to a high switching rate as is required in industrial applications.
- Inductive transducers are available in wide ranges and can be used in several applications.

Disadvantages:

- The shape/composition of the armature (metal to be sensed) plays a role in selecting the transducer. Some times it has to be almost tailor-made.
- The inductive transducer will work metallic (magnetic) material.

Application:

- The most common application of inductive transducer is as proximity switch/sensor which is used in vital equipment as safety devices like cranes, elevators, etc.
- These transducers are also used in process plants to perform programmed sequential functions and counters.
- In monitoring the medical condition of patients, the inductive transducer plays a very important role. As they find use in PB monitors, heart monitors, stethoscope, etc.

Principle of linear variable differential Transformer (LVDT)

The term **LVDT** stands for the **Linear Variable Differential Transformer**. It is the most widely used inductive transducer that converts the linear motion into the electrical signal.

The output across secondary of this transformer is the differential thus it is called so. It is very accurate inductive transducer as compared to other inductive transducers.

Construction:

- The transformer consists of a primary winding P and two secondary windings S_1 and S_2 wound on a cylindrical former (which is hollow in nature and contains the core).
- Both the secondary windings have an equal number of turns, and we place them on either side of primary winding
- The primary winding is connected to an AC source which produces a flux in the air gap and voltages are induced in secondary windings.
- A movable soft iron core is placed inside the former and displacement to be measured is connected to the iron core.
- The iron core is generally of high permeability which helps in reducing harmonics and high sensitivity of LVDT.
- The LVDT is placed inside a stainless steel housing because it will provide electrostatic and electromagnetic shielding.
- The both the secondary windings are connected in such a way that resulted output is the difference between the voltages of two windings.

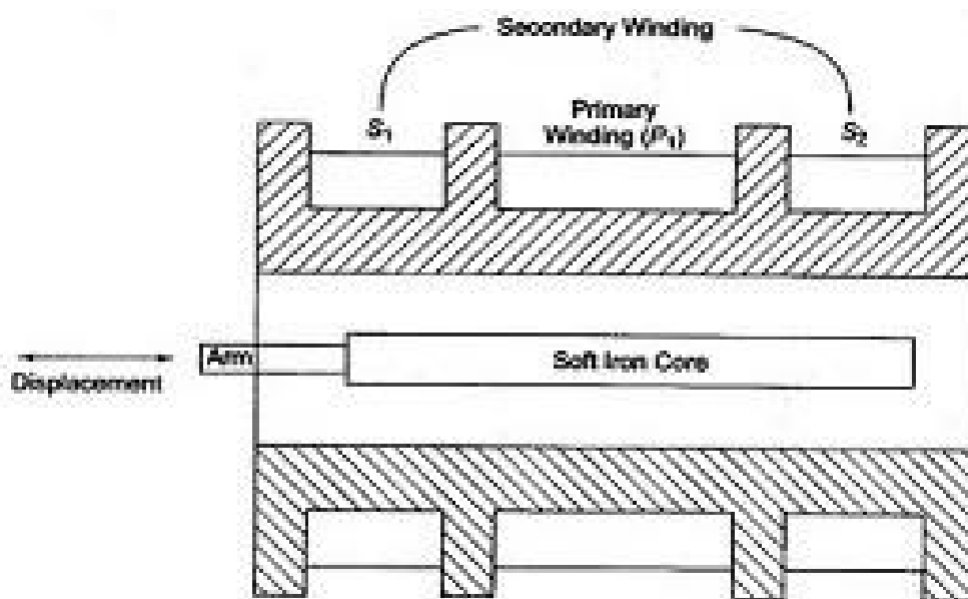

Working of an LVDT

The working of the LVDT circuit diagram can be divided into three cases based on the position of the iron core in the insulated former.

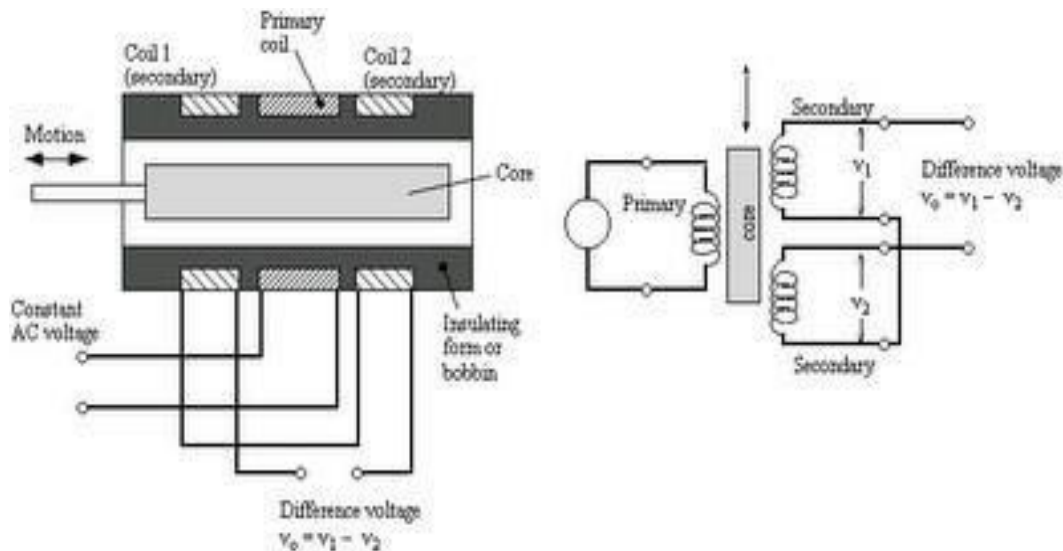

- **In Case-1:** When the core of the LVDT is at the null location, then both the minor windings flux will equal, so the induced e.m.f is similar in the windings. So for no dislocation, the output value (e_{out}) is zero because both the e_1 & e_2 are equivalent.
- **In Case-2:** When the core of the LVDT is shifted up to the null point. In this case, the flux involving minor winding S1 is additional as contrasted to flux connecting with the S 2 winding. Due to this reason, e_1 will be added as that of e_2 . Due to this e_{out} (output voltage) is positive.
- **In Case-3:** When the core of the LVDT is shifted down to the null point, In this case, the amount of e_2 will be added as that of e_1 . Due to this e_{out} output voltage will be negative plus it illustrates the o/p to down on the location point.

Advantages of LVDT

- High Range – The LVDTs have a very high range for measurement of displacement. they can used for measurement of displacements ranging from 1.25 mm to 250 mm
- No Frictional Losses – As the core moves inside a hollow former so there is no loss of displacement input as frictional loss so it makes LVDT as very accurate device.
- High Input and High Sensitivity – The output of LVDT is so high that it doesn't need any amplification. The transducer possesses a high sensitivity which is typically about 40V/mm.
- Low Hysteresis – LVDTs show a low hysteresis and hence repeatability is excellent under all conditions

- Low Power Consumption – The power is about 1W which is very as compared to other transducers.
- Direct Conversion to Electrical Signals – They convert the linear displacement to electrical voltage which are easy to process

Disadvantages of LVDT

- LVDT is sensitive to stray magnetic fields so it always requires a setup to protect them from stray magnetic fields.
- LVDT gets affected by vibrations and temperature.

It is concluded that they are advantageous as compared than any other inductive transducer.

Use of LVDT:

1. We use LVDT in the applications where displacements to be measured are ranging from a fraction of mm to few cms. The **LVDT** acting as a primary transducer converts the displacement to electrical signal directly.
2. The LVDT can also act as a secondary transducer. E.g. the Bourbon tube which acts as a primary transducer and it converts pressure into linear displacement and then LVDT converts this displacement into an electrical signal which after calibration gives the readings of the pressure of fluid.
3. The LVDT sensor works as the main transducer, and that changes displacement to an electrical signal straight..
4. LVDT is used to measure the weight, force, and also pressure
5. In ATMs for Dollar bill thickness
6. Used for soil moisture testing
7. In machines for making PILLS
8. Robotic cleaner
9. It is used in medical devices for brain probing
10. Some of these transducers are used to calculate the pressure and load
11. LVDT's are mostly used in industries as well as servomechanisms.
12. Other applications like power turbines, hydraulics, automation, aircraft, and satellites

Capacitive Transducer:

- Capacitive Transducer is a device which changes its capacitance with change in the physical phenomena to be measured. It is a passive transducer which required external source of supply to function.

- The transduction element of capacitive transducer is a capacitor which may be a parallel plate, cylindrical or angular capacitor. It is commonly used for the measurement of linear displacement.

General principle of capacitive transducer.

The working principle of capacitive transducer is based on the capacitance of parallel plate capacitor. The capacitance (C) of a parallel plate capacitor with plate area A separated by distance d is given as below.

$$C = \epsilon_0 \epsilon_r A / d \dots\dots\dots (1)$$

Where ϵ_0 and ϵ_r are the permittivity of free space and the relative permittivity of the dielectric material of capacitor.

A typical parallel plate capacitor with a dielectric material in between the plate is shown in the figure below.

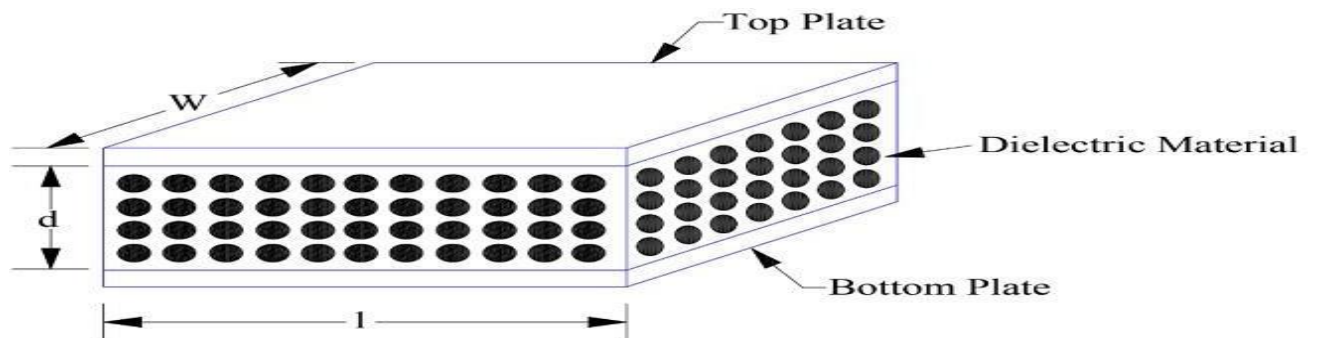

The capacitive transducer works on the principle that the capacitance can be varied by varying the following:

- Area of plate
- Separation between the plates
- Changing the dielectric material between the plates.

In capacitive transducer, the above changes are caused by physical variables like linear displacement, angular displacement, force, pressure and level of liquid.

Variable area capacitive transducer:

The equation below shows that the capacitance is directly proportional to the area of the plates.

$$C = \frac{\epsilon A}{d} = \frac{\epsilon x \omega}{d} F$$

where x – the length of overlapping part of plates
 ω – the width of overlapping part of plates.

The sensitivity of the displacement is constant, and therefore it gives the linear relation between the capacitance and displacement.

$$S = \frac{\partial C}{\partial x} = \epsilon \frac{\omega}{d} F/m$$

The capacitive transducer is used for measuring the angular displacement. It is measured by the movable plates shown below. One of the plates of the transducer is fixed, and the other is movable.

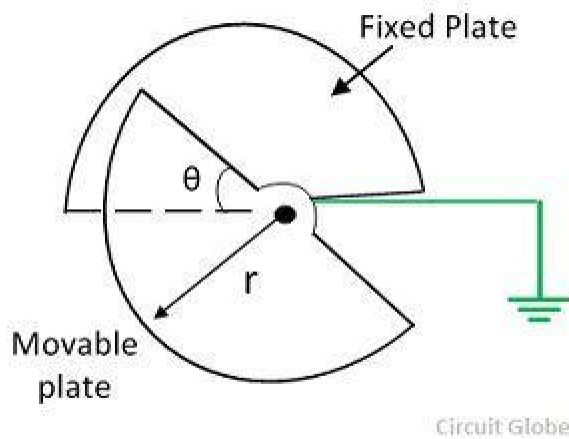

The phasor diagram of the transducer is shown in the figure below.

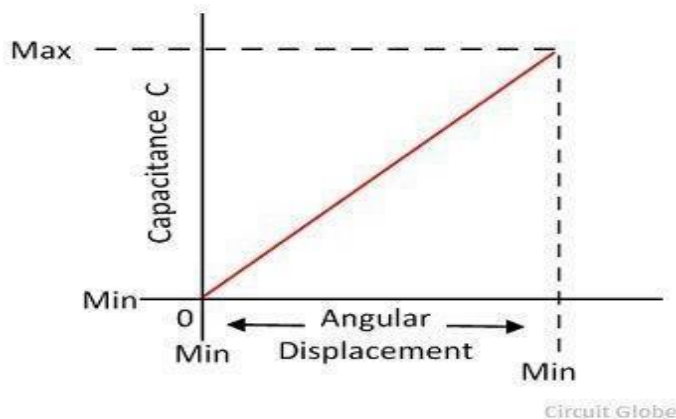

The angular movement changes the capacitance of the transducers. The capacitance between them is maximum when these plates overlap each other. The maximum value of capacitance is expressed as

$$C_{max} = \frac{\epsilon A}{d} = \frac{\pi \epsilon r^2}{2d}$$

The capacitance at angle θ is given expressed as,

$$C = \frac{\epsilon \theta r^2}{2d}$$

θ – angular displacement in radian. The sensitivity for the change in capacitance is given as

$$S = \frac{\partial C}{\partial \theta} = \frac{\epsilon r^2}{2d}$$

The 180° is the maximum value of the angular displacement of the capacitor.

Change in distance between plate capacitive transducer:

The capacitance of the transducer is inversely proportional to the distance between the plates. The one plate of the transducer is fixed, and the other is movable. The displacement which is to be measured links to the movable plates.

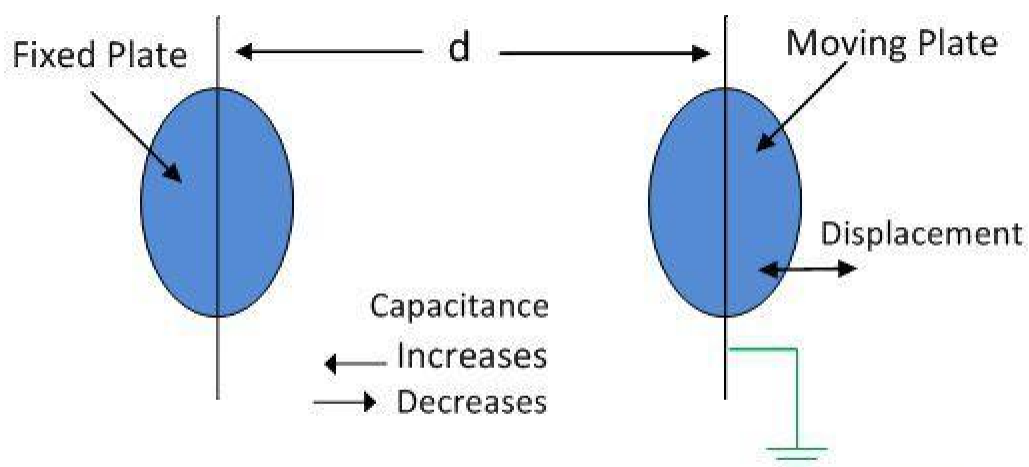

The capacitance is inversely proportional to the distance because of which the capacitor shows the nonlinear response. Such type of transducer is used for measuring the small displacement. The phasor diagram of the capacitor is shown in the figure below.

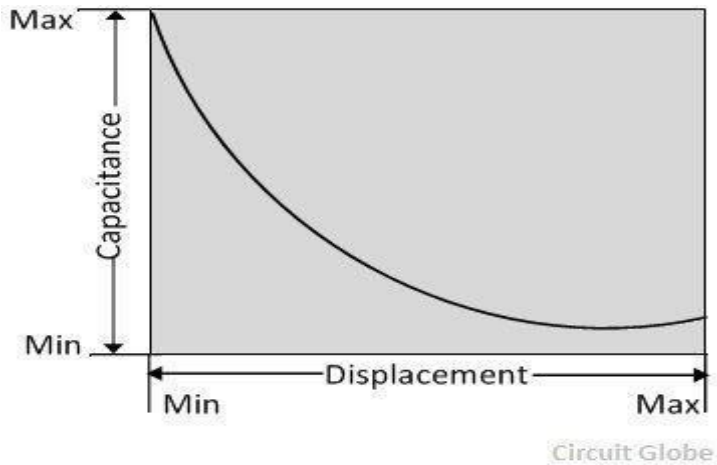

The sensitivity of the transducer is not constant and vary from places to places.

Advantage of Capacitive Transducer

The following are the major advantages of capacitive transducers.

1. It requires an external force for operation and hence very useful for small systems.
2. The capacitive transducer is very sensitive.
3. It gives good frequency response because of which it is used for the dynamic study.
4. The transducer has high input impedance hence they have a small loading effect.
5. It requires small output power for operation.

Disadvantages of capacitive Transducer

The main disadvantages of the transducer are as follows.

1. The metallic parts of the transducers require insulation.
2. The frame of the capacitor requires earthing for reducing the effect of the stray magnetic field.
3. Sometimes the transducer shows the nonlinear behaviours because of the edge effect which is controlled by using the guard ring.

4. The cable connecting across the transducer causes an error.

Uses of Capacitive Transducer

The following are the uses of capacitive transducer.

1. It is used as a pressure transducer in some cases, where the dielectric constant of the transducer changes with the pressure.
2. The humidity in gases is measured through the capacitive transducer.
3. The transducer uses the mechanical modifier for measuring the volume, density, weight etc.

Piezo electric Transducer and Hall Effect Transducer with their applications.

Piezo electric Transducer:

A **piezoelectric transducer** (also known as a piezoelectric sensor) is a device that uses the piezoelectric effect to measure changes in acceleration, pressure, strain, temperature or force by converting this energy into an electrical charge.

Piezoelectric Transducer Working

Piezoelectric Transducer working is based on the principle of piezoelectricity. The root of piezoelectric material, usual quartz, is covered with a thin layer of conducting material like silver. But at first, we must explain the role of quartz crystals in Transducers. A piezoelectric transducer contains quartz crystal which is constructed from silicon and oxygen ordered in the crystalline system (SiO₂). Typically, the main cell (basic repeating unit) of all crystal is uniform and symmetric but not in piezoelectric quartz crystals. Piezoelectric crystals are electrically unbiased and neutral.

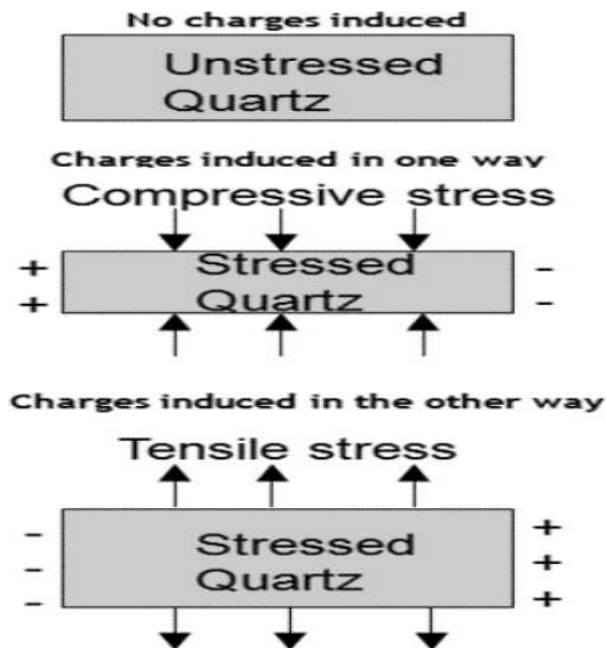

Advantages:

1. Very high frequency response.
2. Self generating, so no need of external source.
3. Simple to use as they have small dimensions and large measuring range.
4. Barium titanate and quartz can be made in any desired shape and form. It also has a large dielectric constant. The crystal axis is selectable by orienting the direction of orientation.

Disadvantages:

1. It is not suitable for measurement in static condition.
2. Since the device operates with the small electric charge, they need high impedance cable for electrical interface.
3. The output may vary according to the temperature variation of the crystal.
4. The relative humidity rises above 85% or falls below 35%, its output will be affected. If so, it has to be coated with wax or polymer material.

Applications:

1. Due to its excellent frequency response, it is normally used as an accelerometer, where the output is in the order of (1-30) mV per gravity of acceleration.

2. The device is usually designed for use as a pre-tensional bolt so that both tensional and compression force measurements can be made.
3. Can be used for measuring force, pressure and **displacement** in terms of voltage

Hall Effect Transducer:

The hall effect element is a type of transducer used for measuring the magnetic field by converting it into an emf. The direct measurement of the magnetic field is not possible. Thus the Hall Effect Transducer is used. The transducer converts the magnetic field into an electric quantity which is easily measured by the analogue and digital meters.

Principle of Hall Effect Transducer

The principle of hall effect transducer is that if the current carrying strip of the conductor is placed in a transverse magnetic field, then the EMF develops on the edge of the conductor. The magnitude of the develop voltage depends on the density of flux, and this property of a conductor is called the Hall effect. The Hall effect element is mainly used for magnetic measurement and for sensing the current.

Consider the hall effect element shown in the figure below. The current supply through the lead 1 and 2 and the output is obtained from the strip 3 and 4. The lead 3 and 4 are at same potential when no field is applied across the strip.

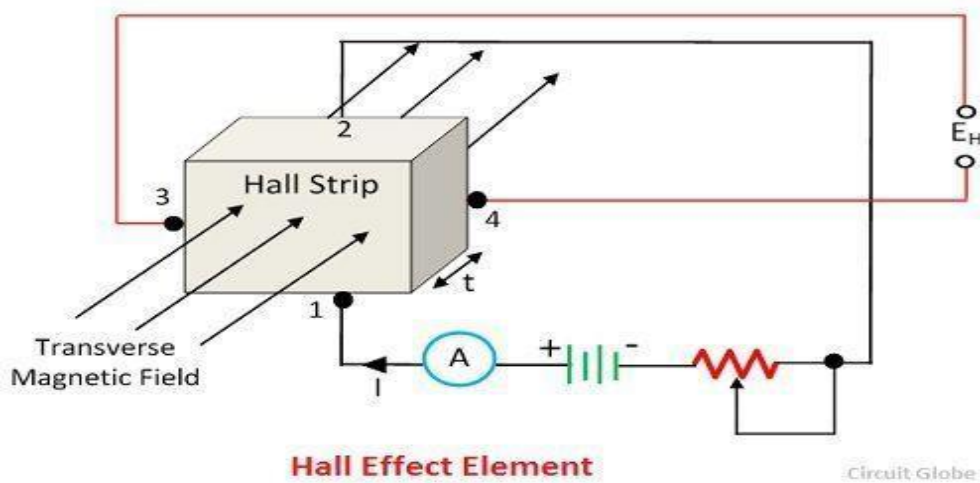

When the magnetic field is applied to the strip, the output voltage develops across the output leads 3 and 4. The developed voltage is directly proportional to the strength of the material.

The output voltage is,

$$E_H = K_H IB/t$$

where,

$$K_H - \text{Hall effect coefficient ; } \frac{V - m}{A - Wbm^{-2}}$$

$$t - \text{thickness of Strip ; m}$$

The I is the current in ampere and the B is the flux densities in Wb/m²

The current and magnetic field strength both can be measured with the help of the output voltages. The hall effect EMF is very small in conductors because of which it is difficult to measure. But semiconductors like germanium produces large EMF which is easily measured by the moving coil instrument.

Applications of Hall Effect Transducer

The following are the application of the Hall effect Transducers.

1. Magnetic to Electric Transducer – The Hall effect element is used for converting the magnetic flux into an electric transducer. The magnetic fields are measured by placing the semiconductor material in the measured magnetic field. The voltage develops at the end of the semiconductor strips, and this voltage is directly proportional to the magnetic field density.

The Hall Effect transducer requires small space and also gives the continuous signal concerning the magnetic field strength. The only disadvantage of the transducer is that it is highly sensitive to temperature and thus calibration requires in each case.

3. Measurement of Displacement – The Hall effect element measures the displacement of the structural element. **For example** – Consider the ferromagnetic structure which has a permanent magnet.

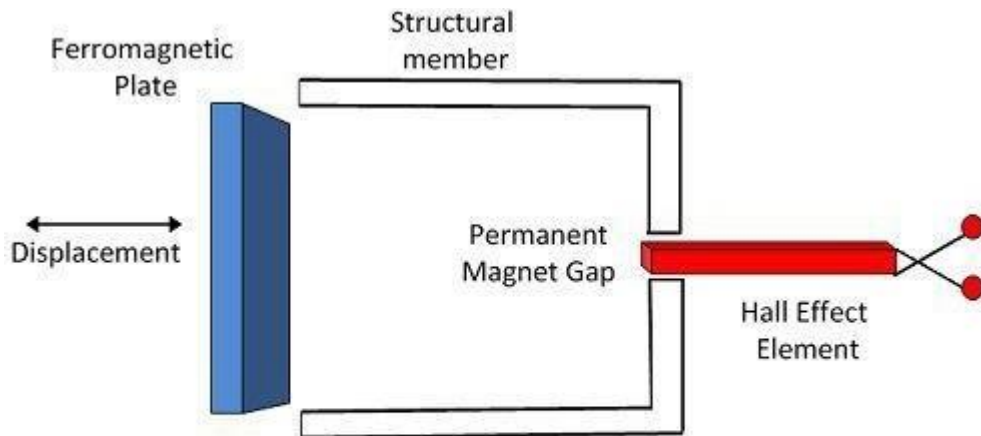

Measurement of Displacement Using Hall Effect Transducer

Circuit Globe

The hall effect transducer is placed between the poles of the permanent magnet. The magnetic field strength across the hall effect element changes by changing the position of the ferromagnetic field.

3. Measurement of Current – The hall effect transducer is also used for measuring the current without any physical connection between the conductor circuit and meter.

The AC or DC is applied across the conductor for developing the magnetic field. The strength of the magnetic field is directly proportional to the applied current. The magnetic field develops the emf across the strips. And this EMF depends on the strength of the conductor.

4. Measurement of Power – The hall effect transducer is used for measuring the power of the conductor. The current is applied across the conductor, which develops the magnetic field. The intensity of the field depends on the current. The magnetic field induces the voltage across the strip. The output voltage of the multiplier is proportional to the power of the transducer.

Short questions with answer:

1) What is Transducer? Writedown its major component?

Ans- Transducer: The **device** which **converts** the **one form of energy** into **another** is known as the **transducer**. The **process of conversion** is known as **transduction**.



The transducer consists two important parts.

5. Sensing Element
6. Transduction Element

2) What do you mean by sensing element and Traduction element?

Ans-Sensing or Detector Element – It is the part of the transducers which give the response to the physical sensation. The response of the sensing element depends on the physical phenomenon.

Transduction Element – The transduction element converts the output of the sensing element into an electrical signal. This element is also called the secondary transducer

3)What is Potentiometer?Also writedown its types?

Ans- The potentiometer is the three terminal device used for measuring the potential differences by manually varying the resistances

There are two main types of potentiometers:

- Angular motion potentiometer
- Linear potentiometer

4) What is thermistor? Writedown two advantages of Thermistor?

Ans- A thermistor (or thermal resistor) is defined as a type of resistor whose electrical resistance varies with changes in temperature.

Thermistors act as a passive component in a circuit. They are an accurate, cheap, and robust way to measure temperature

Advantages-i

- i. Small in size
- ii. Low cost

5) Define gauge factor?

Ans- The **gauge factor of strain gauge** is defined as the unit change in resistance per unit change in length.

i.e. gauge factor $G_f = (\Delta R/R)/(\Delta l/l)$

where, R = nominal gauge resistance,
 ΔR = change in resistance,
 l = length of the specimen in an unstressed condition,
 Δl = change in specimen length.

Long Question:

- 1) Define Transducer. With suitable example classify Transducer?
 - 2) Explain angular motion Transducer?
 - 3) Write a short note on Thermister?
 - 4) Explain the principle of LVDT? Also write down its uses?
 - 5) Write a short note on Piezi electric Transducer?
 - 6) Explain Hall effect Transducer?
-

Chapter 8: OSCILLOSCOPE

Principle of operation of Cathode Ray Tube.

CRT : It stands for Cathode Ray Tube. CRT is a technology used in traditional computer monitors and televisions. The image on CRT display is created by firing electrons from the back of the tube of phosphorus located towards the front of the screen.

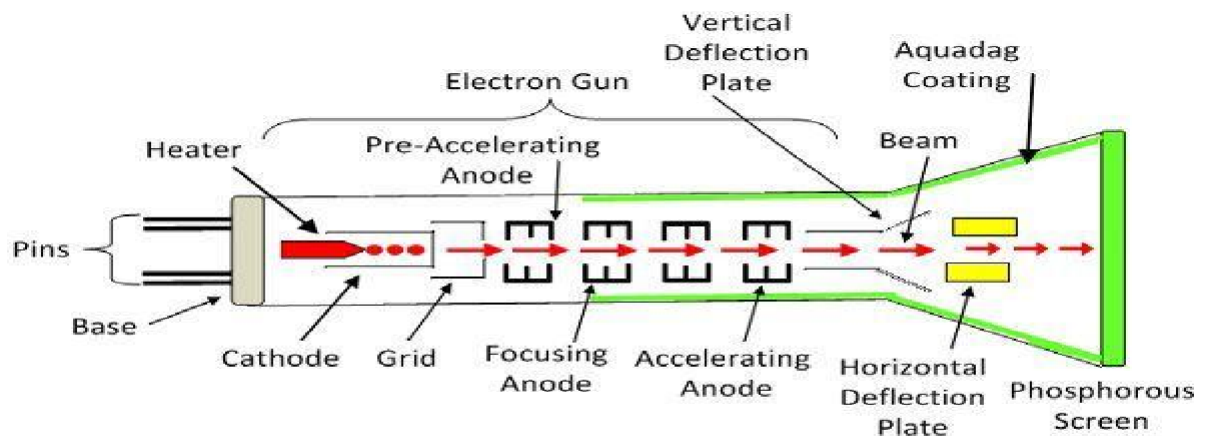

Cathode Ray Tube

Circuit Globe

- o It consists of an electron gun.
- o The electron gun produce an electron beam.
- o The beam is narrow and is allowed to pass down the tube, and to fall on the screen.

- The screen is formed by the flat end of glass tube which is coated with the fluorescent material.
- The point at which the electron beam strikes the screen, a spot is formed.
- The electron beam passes through two pairs of electrostatic deflection plates, the horizontal and vertical deflecting plates. The voltages which are applied to these plates deflect the beam.
- Horizontal deflecting plates move the spot in horizontal direction and vertical deflecting plates move the spot on the screen in vertical and horizontal are independent of each other and thus the beam may be displayed anywhere on the screen.

The main parts of the CRT are:

- Electron gun assembly
- Deflection plate assembly
- Fluorescent screen
- Glass tube
- Base

Advantages of CRT

1. CRT's are less expensive than other display technologies.
2. They operate at any resolution, geometry and aspect ratio without decreasing the image quality.
3. CRTs produce the very best color and gray-scale for all professional calibrations.
4. Excellent viewing angle.
5. It maintains good brightness and gives long life service

Principle of operation of Oscilloscope (with help of block diagram).

Oscilloscope is an electronic equipment, which displays a voltage waveform. Among the oscilloscopes, Cathode Ray Oscilloscope (CRO) is the basic one and it displays a time varying signal or waveform.

Block Diagram of CRO:

Cathode Ray Oscilloscope (CRO) consists a set of blocks. Those are vertical amplifier, delay line, trigger circuit, time base generator, horizontal amplifier, Cathode Ray Tube (CRT) & power supply. The block diagram of CRO is shown in below figure.

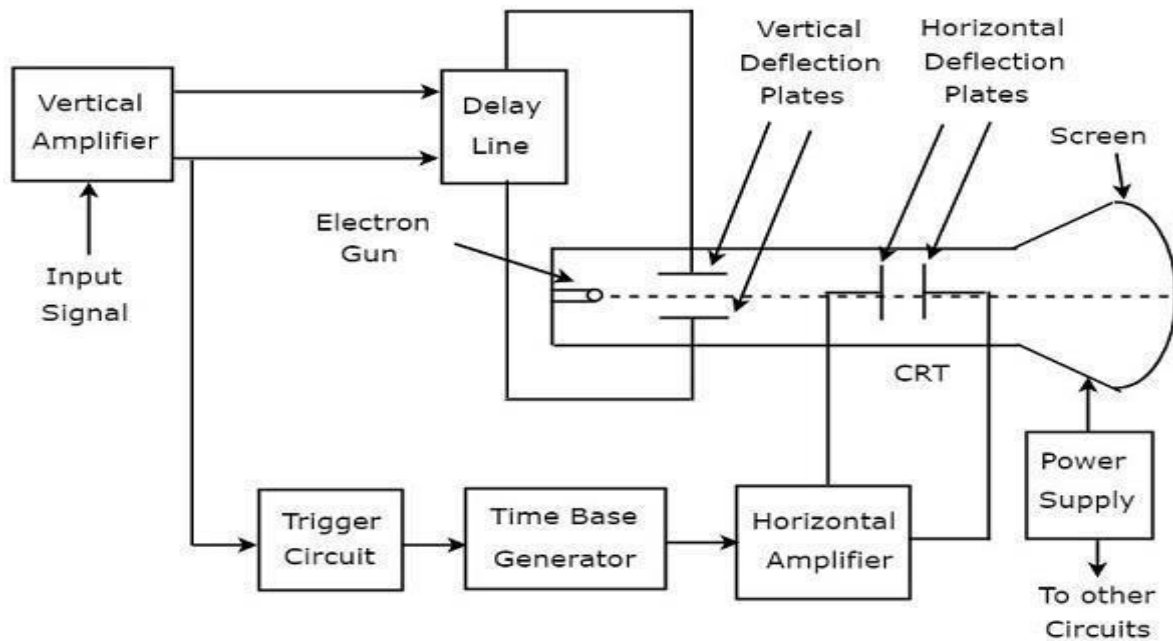

The **function** of each block of CRO is mentioned below.

- **Vertical Amplifier** – It amplifies the input signal, which is to be displayed on the screen of CRT.
- **Delay Line** – It provides some amount of delay to the signal, which is obtained at the output of vertical amplifier. This delayed signal is then applied to vertical deflection plates of CRT.
- **Trigger Circuit** – It produces a triggering signal in order to synchronize both horizontal and vertical deflections of electron beam.
- **Time base Generator** – It produces a sawtooth signal, which is useful for horizontal deflection of electron beam.
- **Horizontal Amplifier** – It amplifies the sawtooth signal and then connects it to the horizontal deflection plates of CRT.
- **Power supply** – It produces both high and low voltages. The negative high voltage and positive low voltage are applied to CRT and other circuits respectively.
- **Cathode Ray Tube (CRT)** – It is the major important block of CRO and mainly consists of four parts. Those are electron gun, vertical deflection plates, horizontal deflection plates and fluorescent screen.

- The electron beam, which is produced by an electron gun gets deflected in both vertical and horizontal directions by a pair of vertical deflection plates and a pair of horizontal deflection plates respectively. Finally, the deflected beam will appear as a spot on the fluorescent screen.

Advantages

- Cost and Timeline
- Training requirements
- Consistency & quality
- Time efficiency
- Expertise & experience
- Capacity for problem-solving

Disadvantages

- These oscilloscopes are expensive as compared with other measuring devices like multimeters.
- They are complicated to repair once it gets damaged.
- These devices need complete isolation
- These are huge, heavy and uses more power
- A lot of control terminals

Uses of CRO

In the laboratory, the CRO can be used as

- It can display different types of waveforms
- It can measure the short time interval
- In voltmeter, it can measure the potential difference

Measurement of DC Voltage & current.

Why Measure DC Voltages With an Oscilloscope Instead of a Meter?

Voltmeters can be quite sluggish (unless you're using an old-fashioned analog meter). In some cases, this sluggishness makes it hard to monitor some voltages. An oscilloscope (scope) has the advantage of instant response. Also, most scopes have two or more channels. Thus you can have two (or more) voltages on the scope's screen and see what's going on with both of them.

Making Voltage Measurements

1. Each probe has an alligator clip for connecting the scope to ground. Connect one of these clips to your circuit's ground.
 - It's not necessary to connect the clip on the other probe.
2. Connect a probe to a point in your circuit that has a voltage you want to measure.

3. If there's another voltage you'd like to measure, connect the other probe to this second point.
4. Each square on the screen's grid is one centimeter. Above, you set the VOLT/DIV knobs to 1 V. This means that each centimeter represents 1 volt, and each smaller division represents 0.2 volts.
5. If the voltage you're measuring is greater than 8 volts, the trace will go off the screen. If this happens, set the VOLT/DIV knob to a larger voltage.
6. An alternative to having the zero points for both traces on the bottom line of the grid, is to have one zero point on the center grid line, and the other on the bottom line. If the voltages you're working with go negative as well as positive, you'll probably want to have one zero point on the line 2 centimeters down from the top and the other on the line 2 centimeters up from the bottom.

Measurement of AC Voltage, current, phase & frequency.

Voltage Measurement.

1. The simplest way to measure signal is to set the trigger button to auto that means oscilloscope start to measure the voltage signal by identifying the zero voltage point or peak voltage by itself. As any of these two points identified the oscilloscope triggers and measure the range of the voltage signal.
2. Vertical and horizontal controls are adjusted so that the displayed image of the sine wave is clear and stable. Now take measurements along the center vertical line which has the smallest divisions. Reading of the voltage signal will be given by vertical control.

Current Measurement

1. Attach a probe with the resistor to an electrical circuit. Make sure that resistor's power rating should be equal or greater than the power output of the system.
2. Now take the value of [resistance](#) and plug into Ohm's Law to calculate the current.
According to [Ohm's Law](#),

Frequency Measurement

1. Increase the vertical sensitivity to get the clear picture of the wave on the screen without chopping any of its amplitude off.

2. Now adjust the sweep rate in such a way that screen displays a more than one but less than two complete cycles of the wave.
3. Now count the number of divisions of one complete cycle on the graticule from start to end.
4. Now take horizontal sweep rate and multiply it with the number of units that you counted for a cycle. It will give you the period of the wave. The period is the number of seconds each repeating waveform takes. With the help of period, you can simply calculate the frequency in cycles per second (Hertz).

Short Question with answer:

1) What is CRT? Also write down the main parts of CRT?

Ans- It stands for Cathode Ray Tube. CRT is a technology used in traditional computer monitors and televisions. The image on CRT display is created by firing electrons from the back of the tube of phosphorus located towards the front of the screen.

The main parts of the CRT are:

- Electron gun assembly
- Deflection plate assembly
- Fluorescent screen
- Glass tube
- Base

2) Draw the block diagram of CRT?

Ans-

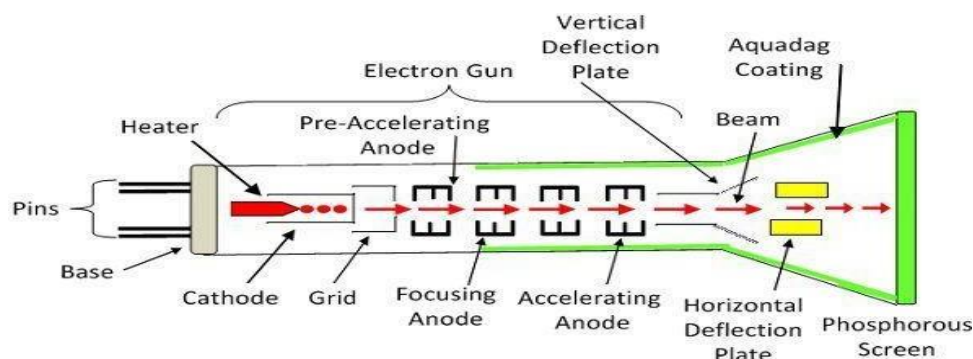

Cathode Ray Tube

3) Draw the block diagram of CRO?

Ans-

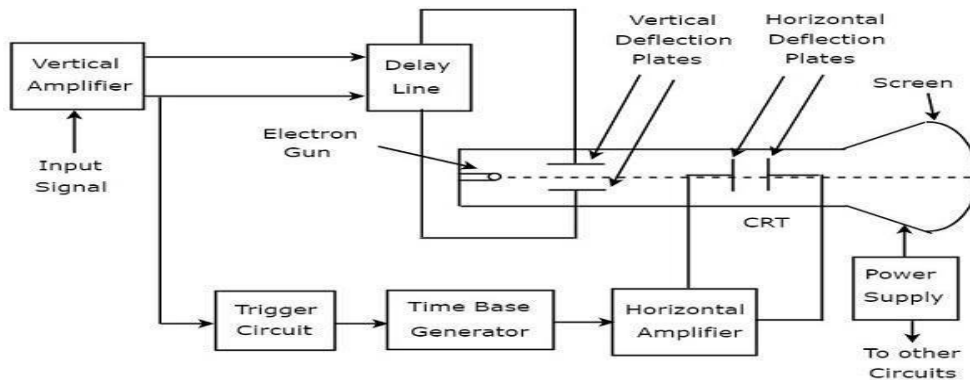

4) Write down the advantages of CRT?

Ans- Advantages of CRT

6. CRT's are less expensive than other display technologies.
7. They operate at any resolution, geometry and aspect ratio without decreasing the image quality.
8. CRTs produce the very best color and gray-scale for all professional calibrations.
9. Excellent viewing angle.
10. It maintains good brightness and gives long life serve

5) Write down the uses of CRO?

Ans- Uses of CRO

In the laboratory, the CRO can be used as

- It can display different types of waveforms
- It can measure the short time interval

Long Question:

1) Explain briefly about CRT?

2) Explain with block diagram the function of CRO?

3) How to measure voltage, current and frequency in an oscilloscope?

